

Nuclear Turbine Plant

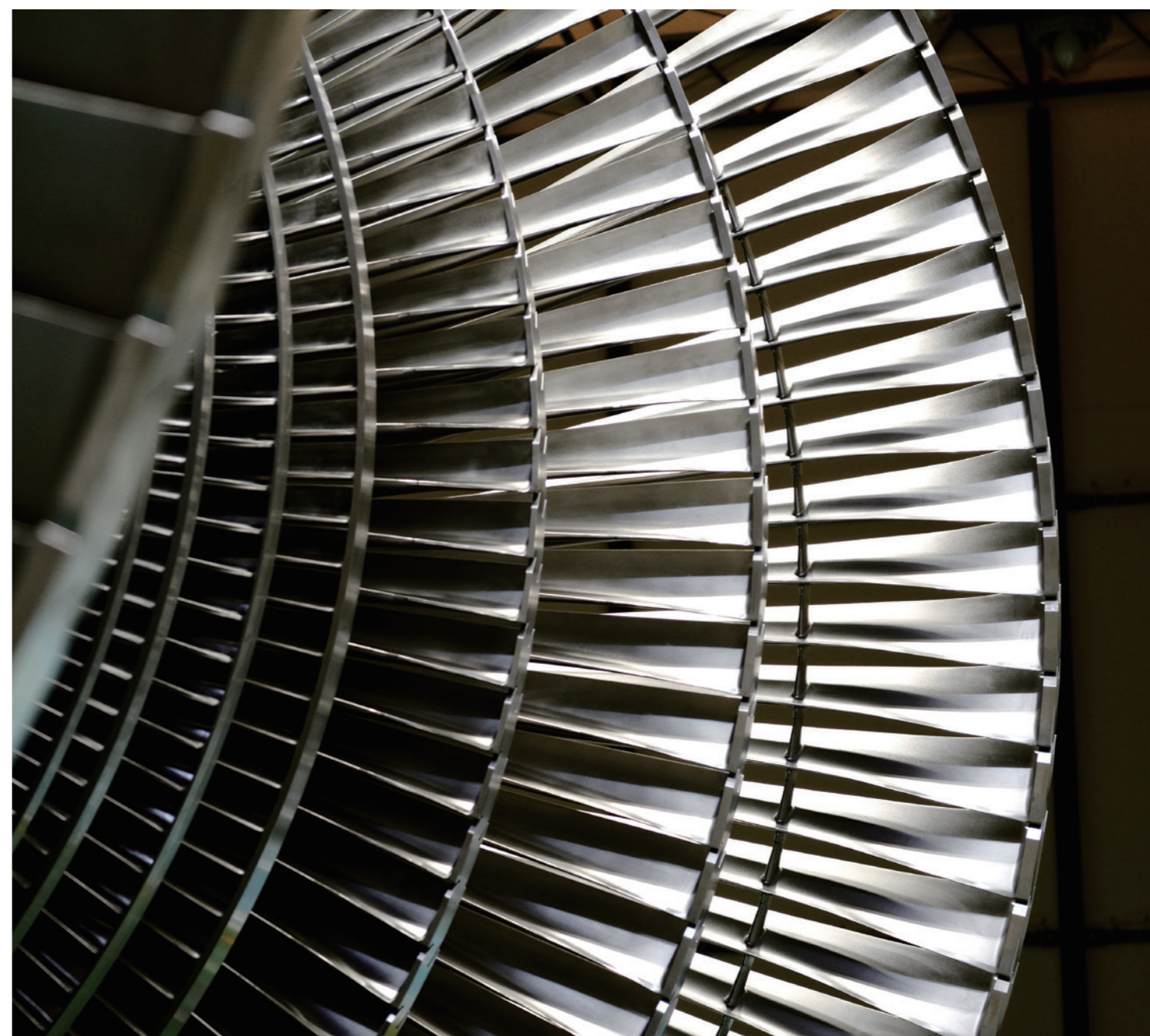

HOW TO POWER THE WORLD

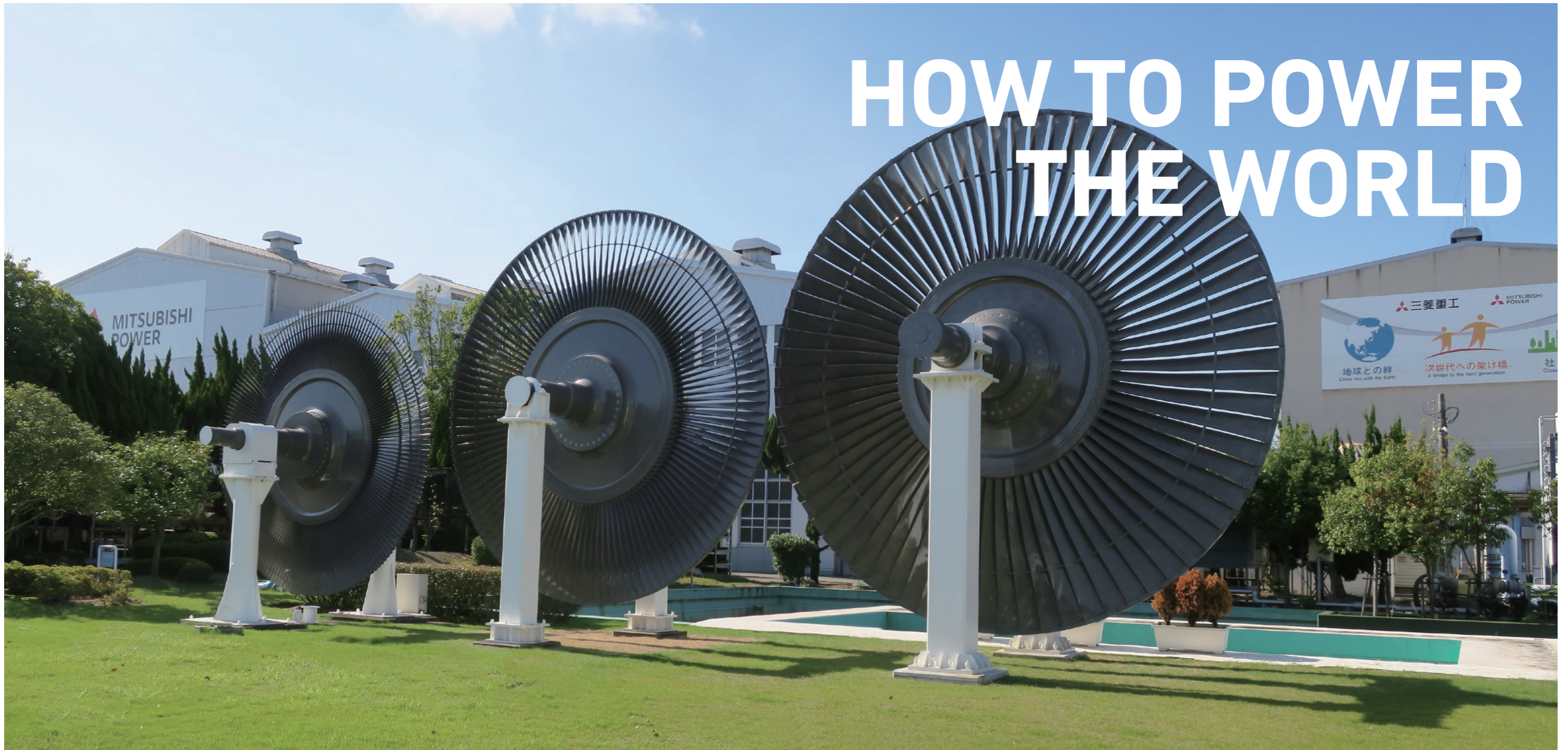

**OUR PLANET IS CALLING FOR
AFFORDABLE, SUSTAINABLE, HIGHLY
RELIABLE AND CLEAN POWER.
TOGETHER WE CAN ACHIEVE IT.**

There is a strong demand for energy decarbonization in the World today. One in ten people is forced to live without reliable access to electricity, while global demand for power continues to grow. Mitsubishi Power, Ltd. addresses such needs by providing stable, highly reliable, and clean energy solutions.

Mitsubishi Power, a core subsidiary of Mitsubishi Heavy Industries Group based on a long history of product development and supply for more than a century, has

been dedicated to designing, manufacturing, verifying, engineering, installing and providing services for a wide range of proprietary power generation systems.

We have rolled out so far 50 years or longer nuclear turbine generators and plants in high reliability and safety, based on advanced Manufacturing Capability, the world highest level of Technical Capability, and Comprehensive Capability ranging from research & development, to engineering, procurement, manufacturing, construction, and after-sales services.

Mitsubishi Power is creating a future that works for people and the planet by developing innovative power generation technology and solutions to enable the decarbonization of energy and deliver reliable power everywhere.

Nuclear Turbine Plants

Mitsubishi Power designs and delivers safe, reliable, efficient, and environmentally friendly nuclear power generation facilities.

Meet Various Requirements & Conditions

Reactor type, Meteorology, Output range

Major Components Manufactured In-House

Turbine, Generator, Heat Exchangers

More than 50 years

Supply and Operation Experiences of Nuclear Turbine Generators



Takahama Nuclear Power Plant



Ikata Nuclear Power Plant



Genkai Nuclear Power Plant



Haiyang Nuclear Power Plant

Nuclear Turbine Plant

Nuclear turbine plant consists of a steam turbine, a generator, and other auxiliaries. The steam turbine receives high pressure and temperature steam from nuclear reactor and converts the heat energy into mechanical energy. The generator converts it into electricity.

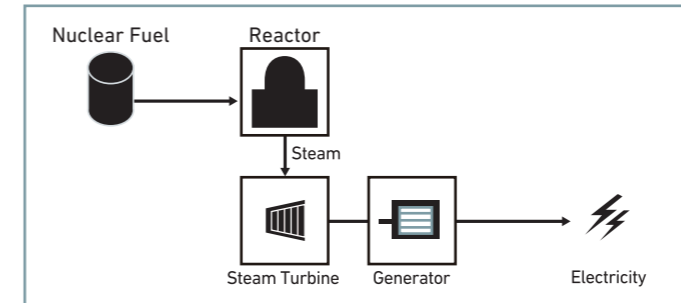

We Meet Customer Requirements & Conditions

Mitsubishi Power offer turbine generators in response to Customers' demands of reactor type, electrical output range, and site meteorological conditions. We also support Customers by implementing feasibility studies at the planning stage of a new project as well as by providing repair, replacement, maintenance services after the commercial operation.

All Our Products Contribute Stable Electricity Supply.

Mitsubishi Power has been supplying turbine generator and turbine plant for nuclear plants since commercial operation of KEPCO (Kansai Electric Power Co.) at Mihama Unit1 in 1970, and assures Customers of long-period of favorable operation track records. We supplied steam turbines for all 24 domestic PWRs and for 12 BWRs, accounting for approx. 80% share of nuclear turbine generator in Japan.

Services not only during plant construction but also after the commercial operation are available from us. Periodic inspection, maintenance and replacement of major components are also widely implemented.

In addition, Mitsubishi Power provided 13 turbines and 5 generators overseas. We have received high reputation of their craftsmanship out there. We have also experienced many Full Turn Key projects abroad are capable for nuclear turbine plant upon experiences of GTCC and steam power projects, in a package proposal.

Major Components manufactured In-House

Engineering and manufacturing for nuclear turbine generators are taken charge by Takasago Works and Hitachi Works out of four production sites of Mitsubishi Power.

Takasago Works design and manufacture steam turbine and large heat exchanger with total plant engineering, construction, commissioning and after-sales services mainly for PWR (Pressurized Water Reactor). Hitachi Works is in charge of design, manufacturing, construction, commissioning and after-sales service of steam turbine, generator and large heat exchanger mainly for BWR (Boiling Water Reactor).

Major components applied in the nuclear turbine use are employed of our own products, contributing to one of the reasons for maintaining high quality. Approximately 4,000 employees are deployed at Takasago Works and approximately 2,000 employees at Hitachi Works, engaging in design and manufacture of combined cycle plants or conventional thermal plants other than nuclear plants. Through efforts to share or utilize component technologies or supply chain, more efficient and more effective promotion of projects has been realized.



Takasago Works



Hitachi Works

Sanmen Nuclear Power Plant 1&2



World's First Nuclear Turbine Generator for 3rd Generation Reactor

Mitsubishi Power announced on October 12, 2018 that the steam turbine generation facilities supplied for the Sanmen nuclear power plant in China have cleared all necessary functional, safety confirmation, and performance tests, with a signing ceremony held on October 11. The Sanmen Nuclear Power Station is the world's first commercial 3rd Generation 1,250 megawatt class pressurized water reactor (AP1000).

The Sanmen nuclear power plant was built by Sanmen Nuclear Power Co., Ltd. (SMNPC) in Sanmen, Zhejiang Province, south of Shanghai. The facility comprises two units, each with an output of 1,250 megawatts. Mitsubishi Power provided the steam turbines, the main valves, moisture separator reheaters (MSR), condensers and other equipment for the two units within the facility under the consortium with Harbin Electric Corporation (HE). The turbine generators being used at Sanmen nuclear power station are our mainstay model with a 54-inch last stage blade. These systems have a proven track record at power plants in Japan, and are now being used in full-fledged operations in China.

The Sanmen Unit 1 began fuel loading at the end of April 2018, and reached 100% output in mid-August. After clearing performance tests and the 168 hours of continuous demonstrated operation additionally required by the Chinese government, the plant began commercial operation in September, 2018. Sanmen Unit 2, accordingly, started commercial operation in November, 2018.

Mr. Miao Yamin, the President of SMNPC, stated in his letter "I would like to convey my sincere gratitude for the support from your excellent team. I look forward to our further collaboration on the future for our mutual interests. May our friendship everlasting!"

Going forward, Mitsubishi Power will continue to contribute to resolving the global issues of stable energy supplies, economic development, and reducing the environmental load by providing steam turbines for safe, reliable, and high-quality nuclear power generation facilities.

Project Summary

Project	Sanmen Nuclear Power Plant Units 1 & 2, China
Customer	Sanmen Nuclear Power Co., Ltd. (SMNPC)
Partner	Harbin Electric Corporation (HE)
Supplied equipment	Steam Turbine, Main Valves, MSR, Condenser, Deaerator, Feedwater Heaters
Electrical Output	1250MWe x 2
Commercial Operation.....	September & November, 2018



Signing Ceremony for Preliminary Acceptance Certificate

(Center) Mr. Miao Yamin, President, SMNPC
 (Right) Mr. Chen Jun, President, HE
 (Left) Mr. Naomiki Hasegawa, Senior Vice President, Mitsubishi Power

World Delivery Records

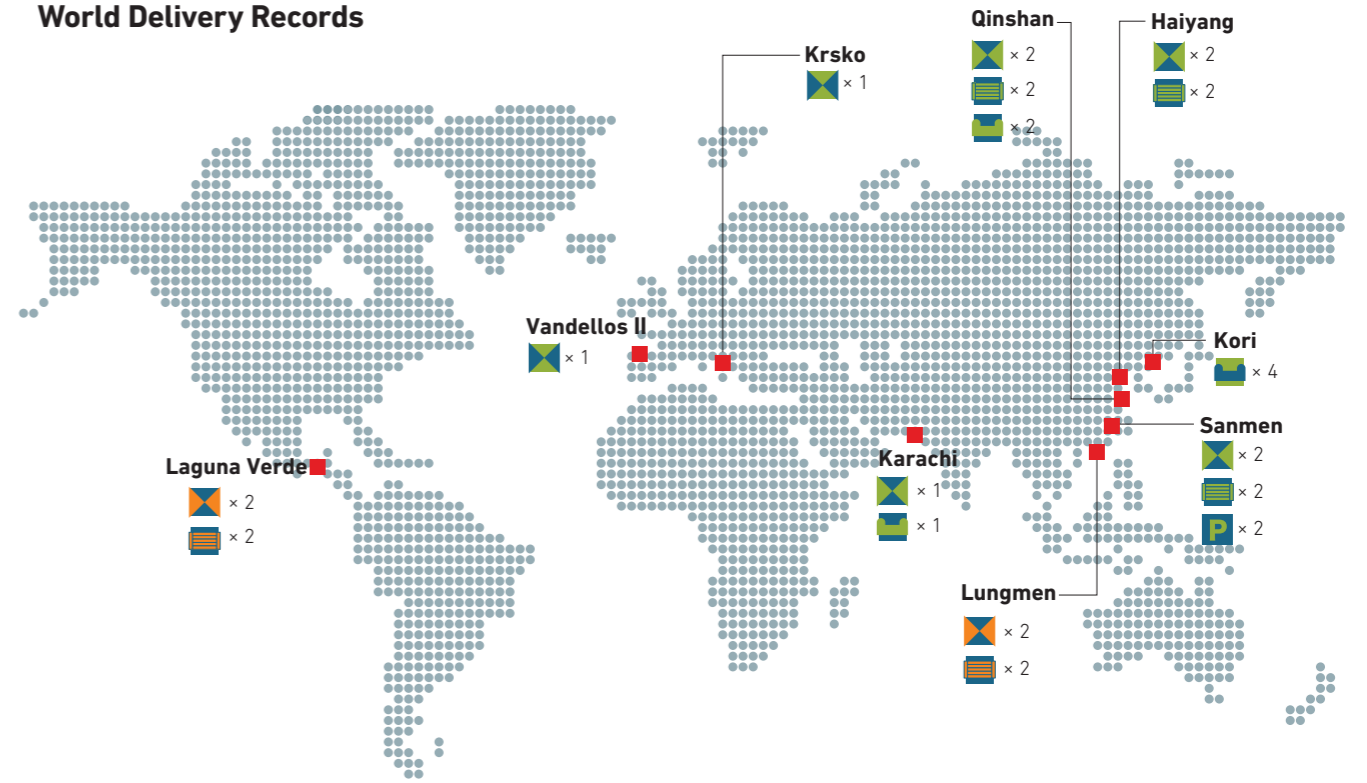

Delivery Records in Japan

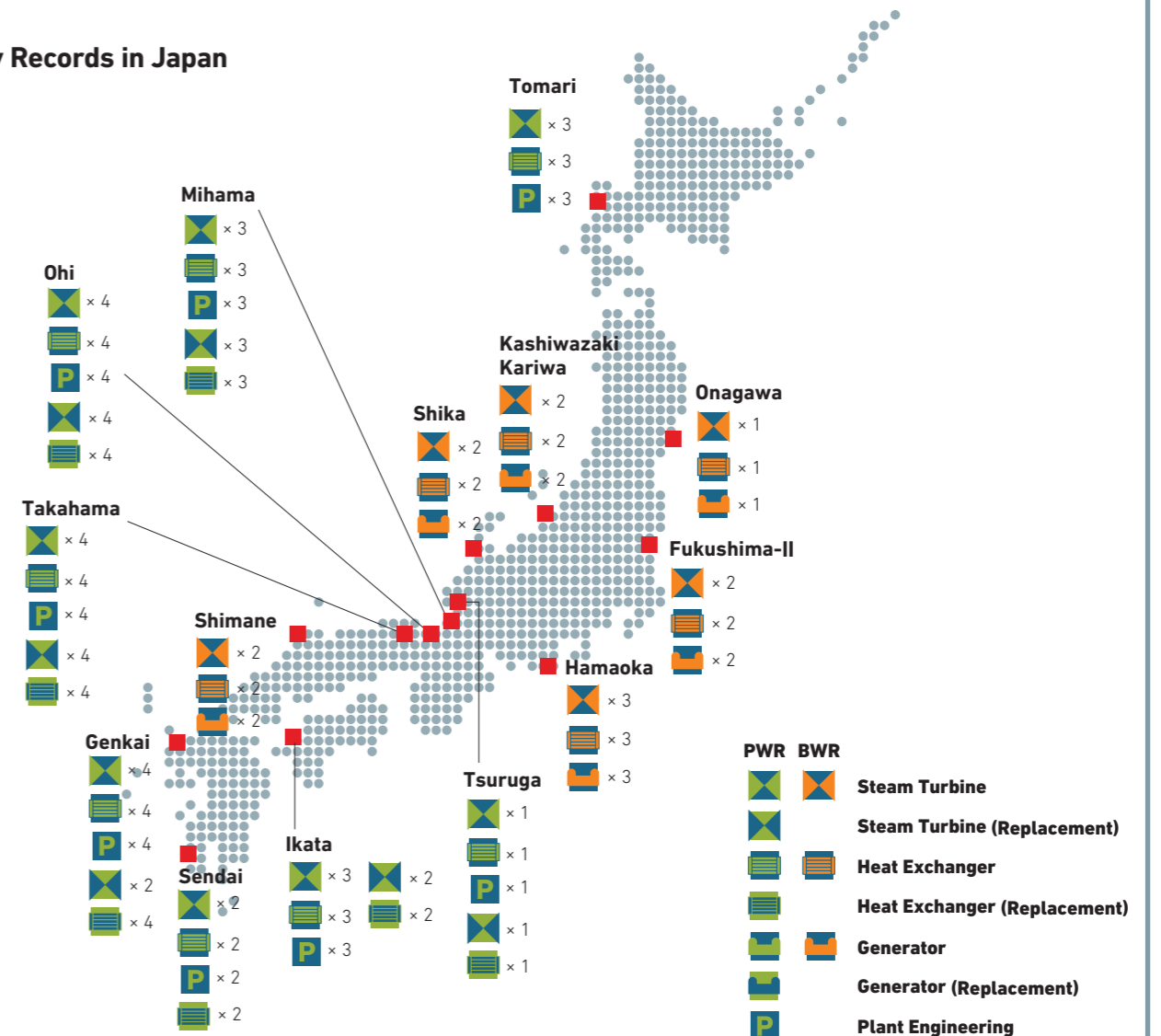

Heat Cycle is Well-Tuned and Optimized.

Recent turbine plant for pressurized water reactor (PWR) employs 2-stage reheat, 7-stage regenerative condensate cycle as standard heat cycle to achieve high efficiency. Turbine plant receives steam from Reactor building and converts its energy to electricity at steam turbine generator. A part of the steam flows to Moisture separator reheater (MSR) in order to reheat main cycle steam. Some amount of steam is extracted from intermediate stage of steam turbines, and is used for heating feedwater at feedwater heaters. Parameters of heat cycle are well tuned and optimized so that maximum efficiency could be achieved.

Below Figure illustrates flow diagram of turbine plant for PWR. Main steam generated at Steam Generator is lead to Turbine building through main steam pipe. Main steam enters into HP turbine through Main Stop Valve (MSV) and Governing Valve (GV) for work, and then it is depressurized. After that, it is reheated at MSR, and goes into LP turbine through Reheat Stop Valve (RSV) and Intercept Valve (ICV). The exhaust steam from LP turbine is condensed at Condenser by cooling water. This condensate is boosted by Condensate pump to Deaerator, and is heated through 4-stage of LP feedwater heaters and at Deaerator. The feedwater from Deaerator is sent to Steam Generator by feedwater pumps through 2-stage of HP feedwater heaters. Steam used for heating main cycle steam or feedwater is condensed into drain. The drain is collected and recovered into feedwater line so that heat efficiency could be increased.

Plant Design achieves High Reliability and Maintainability.

Mitsubishi Power nuclear turbine plant incorporates our long period operational experiences into the system or component design, in order to enhance plant reliability under normal operation. Sufficient design margin is considered in the design and spare machine or backup system is provided. In abnormal events like sudden load drop, a function to protect equipment and to shutdown the plant safely is provided. All necessary corrective actions against past incidents are reflected into the design.

The plant is also designed taking operability and maintainability into account by the stand point of customer. Inspection/maintenance/ replacement of components during operation (in-service inspection: ISI) is available as the necessary space for maintenance and inspection is provided. Sufficient disassembling space is prepared for the components such as steam turbine for overhaul. Two sets of overhead cranes are installed to shorten the inspection period as standard design.

General Arrangement in Turbine Building is so Functional and Optimized

Turbine building that houses turbine plant is steel-framed (underground is reinforced concrete structure), and configured in 4 stories above ground and 1 story underground. (It could be 3 stories above ground and 2 below depending upon site conditions)

Turbine building is non-safety building, but it should be designed such that it could not cause a secondary damage to Reactor building due to external factors like earthquake, floods, inundations or tornados.

Steam turbine and Generator are installed at the 4th floor of the Turbine building with 2 sets of MSR beside. Condenser is installed right beneath LP turbines, and LP feedwater heaters are installed in Condenser shell skirt.

Arrangement of components is studied and determined such that daily inspection/periodical maintenance could be facilitated as well as individual functions of system and components could be satisfied.

We meet with Specific Requirements and Conditions.

Cooling System Optimization: Design of cooling water system differs from meteorological and geographic conditions of the plant site, and largely affects construction/operation costs and layout. Mitsubishi Power offer the most advantageous proposal of cooling water system studying several candidates of the systems.

Physical location of Turbine building: In standard design, Turbine building is oriented so that the turbine shaft is directed toward Reactor building. In the case where site land preparation of this layout is difficult the turbine shaft is oriented 90 degrees towards the Reactor building. Mitsubishi Power can apply either layout of Turbine Building with the study of routing of cooling water pipe from / to intake & discharge pit.

Personnel Friendly Design: Saving operator's load is given as one of Customer needs recently. Our turbine plant is designed such that start and stop operation of major auxiliary components like pumps, open/close of large valves, and operation of frequently used components can be remotely operated from the Main Control Room. Moreover, function to automatically collect principal operation data at main control room could be provided.

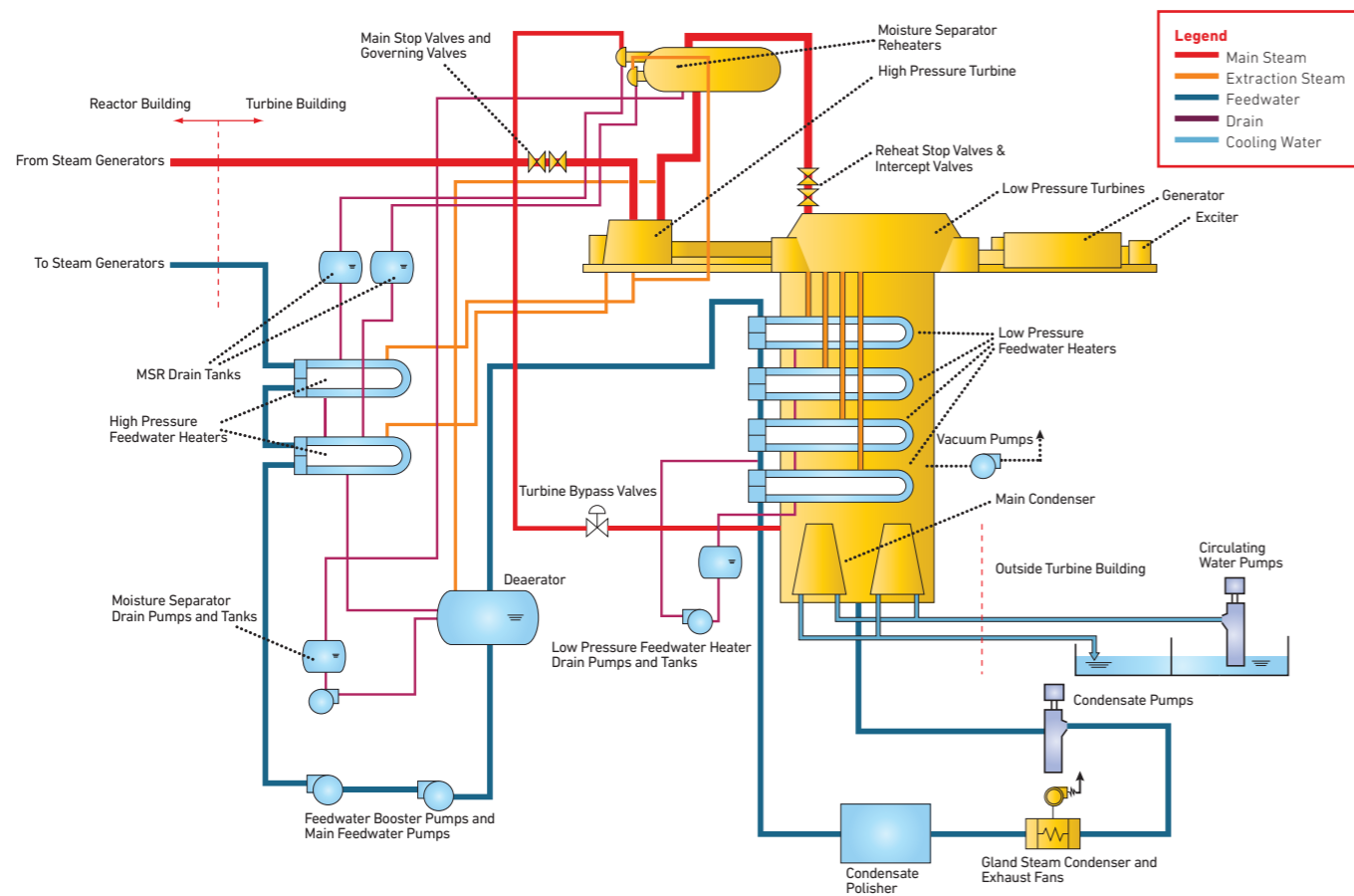

Nuclear Turbine Plant System Flow Diagram for PWR

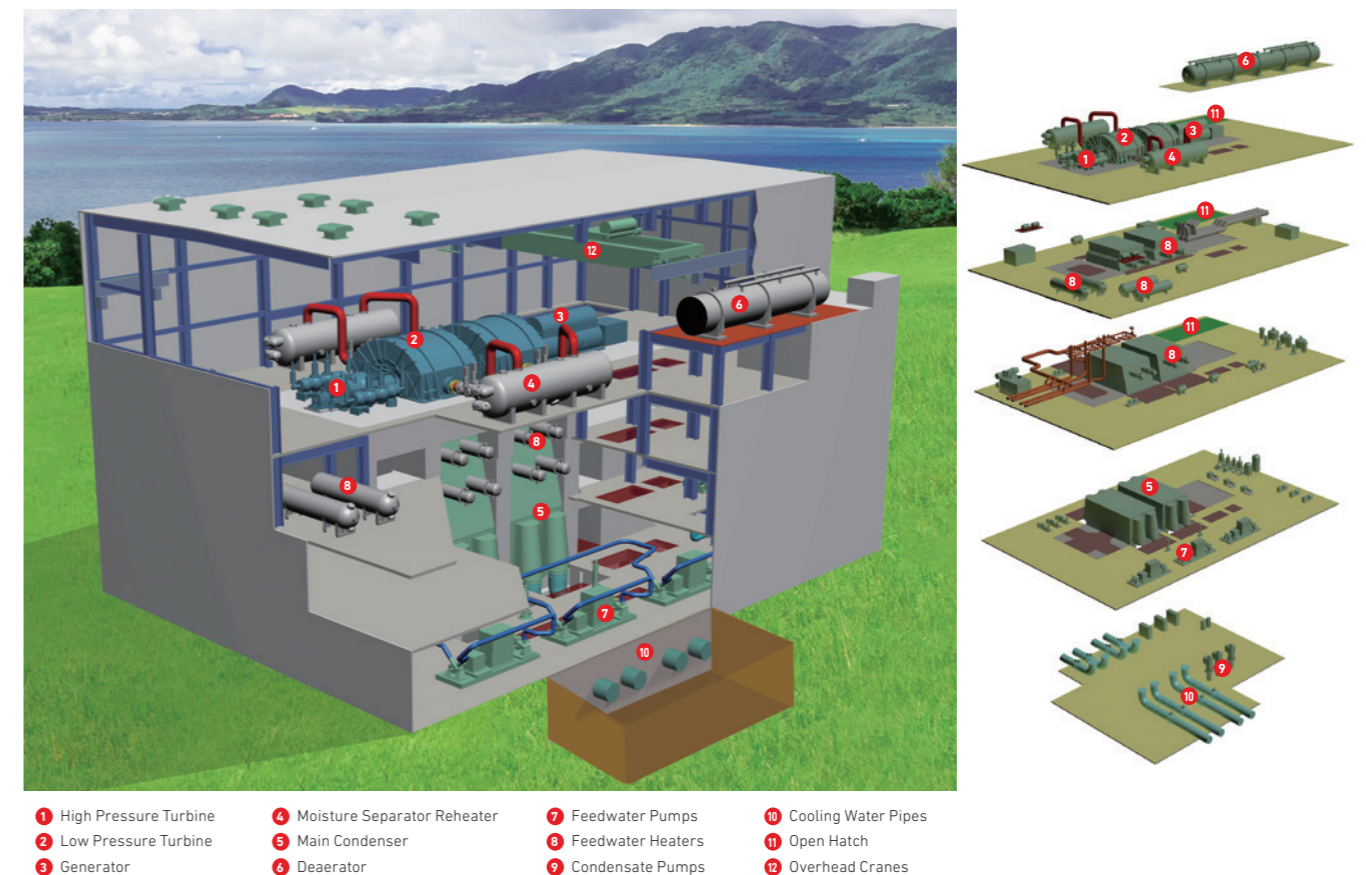

Turbine Building and Component Layout for PWR

Steam Turbine

Steam turbine is the core component in turbine plant, which principally governs reliability and performance of whole plant.

Mitsubishi Power is continuously developing advanced technologies.

Continual Development of
World's Cutting Edge Technologies

Comprehensive Verification
before Field Application

High Quality Manufacturing

Continual Development of World's Cutting Edge Technologies

Mitsubishi Power always develops its expertise to achieve the world's highest level of efficiency and reliability. We create state-of-the-art

component technology, satisfying customer requirements in partnership with R&D center of MHI. We have come up with advanced blade by designing and analyzing with the use of CFD (Computational Fluid Dynamics) and FEM (Finite Element Method), and/or by carrying out tests/experiments, which are applied to our products.

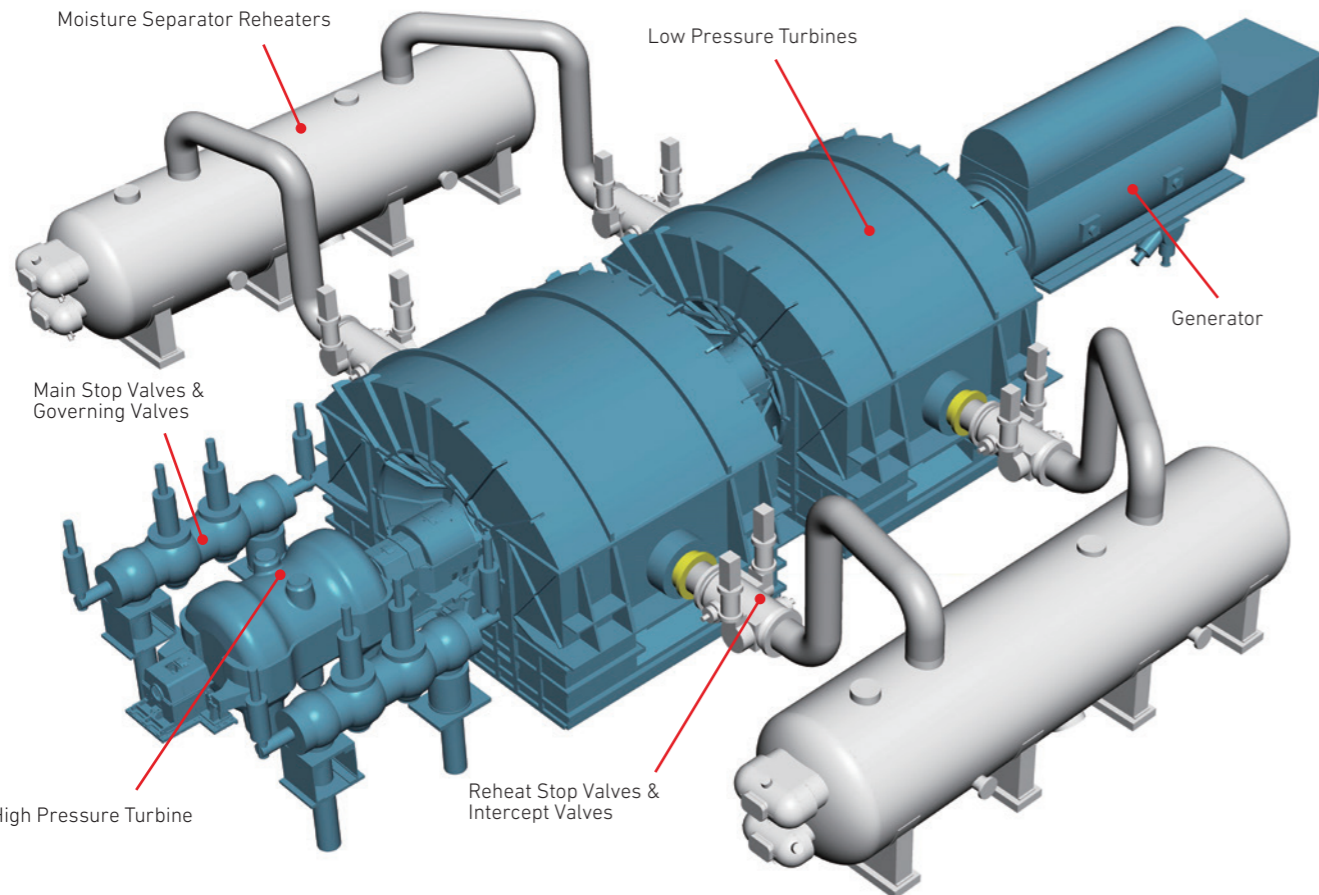

Steam Turbine Generator Outline (TC4F)

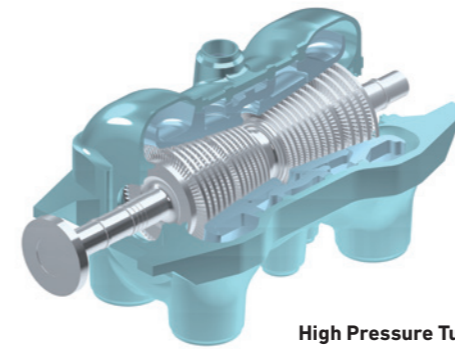

High Pressure Turbine

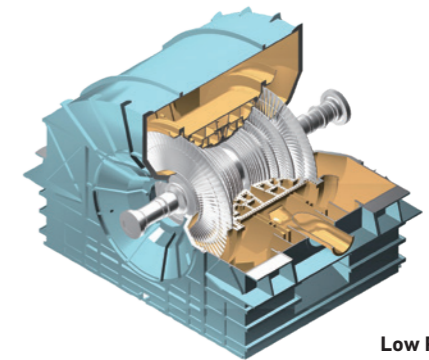

Low Pressure Turbine

World's Longest Class Last Blade and Various Line-ups enhance the performance.

Last-stage rotating blade is abundant with its line-ups in order to meet various kinds of electrical output range to cope with reducing low-pressure turbine exhaust loss. We offer upto world's longest class 74 inch last blade according to plant application.

Steam Turbine Output Ranges

For 50Hz Machine(1,500rpm)

Last stage blades (in.)	Output (MWe)								
	400	600	800	1000	1200	1400	1600	1800	
49	TC4F		TC6F						
54	TC4F		TC6F						
65	TC4F		TC6F						
74	TC4F		TC6F						

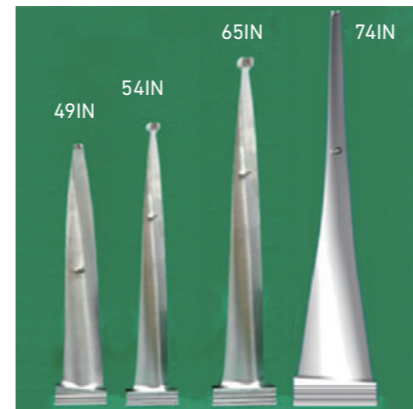
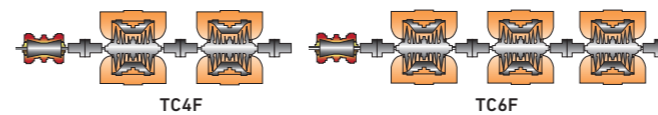

Last Stage Blade Line-ups

Highly Efficient F3D Blades are applied.

F3D (Fully Three Dimensional) blades in which loss is minimized to the utmost limit have been adopted for rotating and stationary blades.



F3D Blade

Low Vibration has been achieved by ISB/CCB Blade Structure.

Such structure as ISB (Integral Shroud Blade)/CCB (Continuous Cover Blade) retaining excellent vibration resistance and yet superior damping characteristic are adopted in all blades including low-pressure turbine last-stage blades. This allows reduction of vibratory stress on conventional blade to 1/5 through 1/10.

Large Root and Groove Design minimize SSC risk.

Blade root and groove are upsized compared with conventional blades in order to reduce centrifugal stress. Especially, SCC resisting performance in corrosive environment has been phenomenally upgraded.

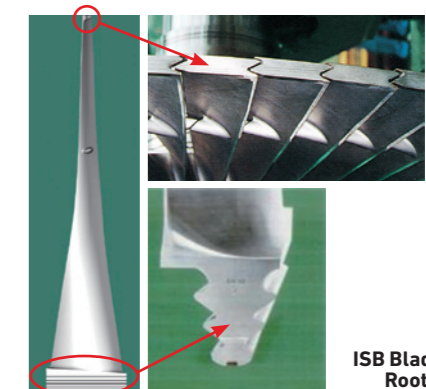

ISB Blade with Large Root & Groove

Both Mono-Block and Welded Rotor are available.

Mono-block rotor or welded rotor is adopted for nuclear turbine rotor used in corrosive environment. Concerns over SSC have been largely eliminated by reducing disc stress by abolishing shrunk-on and keyway disc structure.



Welded Rotor (for thermal plant)



Mono-block Rotor (for thermal plant)

Comprehensive Verification before Field Application

At Mitsubishi Power, newly developed technology is well verified prior to being applied to actual plants to secure its reliability. In particular, the verification process of new turbine blade is established and proven through experiences of developing as many as 15 types of blades for the past 22 years.

Loading test by using steam is implemented at our Actual Loading Test Facility after 3D FEM simulation and flow pattern analysis. Vibration characteristics and performance are verified under the severer conditions than actual operating conditions with a 1/2 scale or larger test turbine.



Actual Loading Test Facility



Turbine Rotor for Actual Loading Test

Full scale test rotor is fabricated and tested to verify rotational vibration characteristics finally. Our Rotation Vibration Test Facility is capable to test rotors of 350tons, up to 8m diameter. This test is also carried out for each actual rotor before shipment.

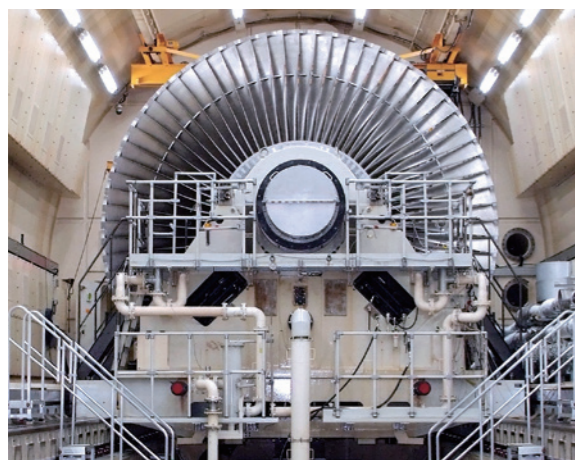

Rotational Vibration Testing Facility

Mitsubishi Power owns combined cycle power plant (T-Point 2) at the premises in order to verify performances and long-term operation reliability. (see COLUMN next page)

High Quality Manufacturing

Strict quality assurance and control criteria is applied at our own shop for nuclear products like turbine rotor, blade and casing etc. In 2009, full-pledged factory exclusively for nuclear turbine was launched eyeing to enhance its quality further. In this factory, large rotor processing facility, large rotor welding facility and blade groove processing facility are equipped, enabling to manufacture eight pieces of nuclear turbine rotors a year. In addition, such equipment as 10,000ton class high pressure press facility and high-speed balance test facility, automated welding equipment and heat treatment facility are also available at Mitsubishi Power for integrated production.



Nuclear Turbine Shop



Inside of Nuclear Turbine Shop

Generator

Realizing Outstanding Reliability and Efficiency with Proven Technologies.

Large Capacity
available
Upto 2000MVA

**H₂ Cooling
+ Water Cooling for
Stator Windings**

**Comprehensive
Verification**

Mitsubishi Power manufactures large capacity Generator for nuclear power plants.

Generator is directly coupled with steam turbine rotor, and converts dynamic energy from steam turbine into electrical energy. Generator mainly consists of stator and rotor having core and coil. Hydrogen, superior in cooling characteristics, is used as coolant. It cools down rotor windings and stator core by ventilating autonomously with help of cooling fan fixed to the rotor. In addition, cooling water is provided to cool stator winding through hollow copper, where large current flows.

Design of Generator is well evaluated by applying the latest technology and tools in electromagnetics, thermodynamics, hydrodynamics, vibrational dynamics, and mechanical engineering, and is verified through design review. Strict quality control is implemented in each manufacturing process of machining and assembly, especially for insulation and electrical work which enhance reliability. At the last stage of manufacturing, stator and rotor of Generator are assembled

at our own shop, and tested in accordance with international codes & standards to demonstrate the performance meets the requirements.

Mitsubishi Power has experiences of large capacity Generator having as much as approx. 1,600 MVA. We are still continuing development of advanced technology so that we can cope with further upscaling of nuclear plant.



presented by Chubu Electric Power
1570MVA Nuclear Turbine Generator

COLUMN

Validation Facility T-Point 2

T-Point 2 is cutting edge combined cycle power plant validation facility with its combination of gas turbine and steam turbine. By developing next-generation technologies and validating them in T-Point 2, Mitsubishi Power helps its customers world-wide attain a stable electricity supply.

Long term demonstration of off-site plant control at T-Point 2 is conducted from the Mitsubishi Power Takasago RMC (Remote Monitoring Center). Validation operations are run to increase the reliability of the entire plant including the main equipment such as turbines as well as auxiliary equipment such as pumps and fans. In addition, various applications of TOMONI™ digital suite of solutions that serve to shorten start-up time and automatically optimize operation parameters are installed in T-Point 2. Mitsubishi Power will also be training its AI applications, allowing T-Point 2 to eventually become the world's first autonomous combined cycle plant.



Item	T-Point 2
Output (5°C air temperature)	566MW
Gas Turbine Type	M501JAC
Turbine Inlet Temperature	1,650°C
Year Operation Started	2020

Heat Exchangers

Beyond half a century experience, Mitsubishi Power heat exchanger for nuclear power plant acquires optimized design, enhanced reliability, and advanced performance.

Large Size
Condenser

Simplified
Moisture Reheater Separator

Feedwater Heaters, Deaerator,
and others

Condenser

Condenser maintains low pressure turbine back pressure (vacuum) by condensing exhaust steam from low pressure turbine through cooling water.

Design conditions of Condenser come with abundant variations depending on various site conditions of power plants. Tube bundle arrangement that affects condensation performance is optimally designed, taking into account steam flow, inundation or sub-cooling etc. Two types of tube bundle arrangements are available; one is radial flow arrangement where steam flows towards the center of tube bundle, and the other is down flow arrangement where steam flows downward. Cooling tube use titanium tube with erosion/corrosion resistant thin wall as standard, but if cooling water is fresh water, stainless tube might be selected. Cooling tubes are expanded and seal welded to tubesheets to avoid leak.

Inside the shell-skirt of Condenser, LP (Low Pressure) feedwater heaters are installed. (Neck heater) This contributes to compact turbine building, to shorten the length of extraction pipe and feedwater pipe, and to minimize steam pressure drop through extraction pipe to LP feedwater heaters. Turbine bypass pipe is installed so that the excess steam during plant transient conditions could be dumped into Condenser.

Water box, tubesheet, cooling tube and tube support plates are arranged at the shell, where low pressure turbine exhaust steam is condensed. The condensate is collected in hotwell which takes a role as reservoir for Condensate Pump, as well as receiver of excess drains at abnormal operation.

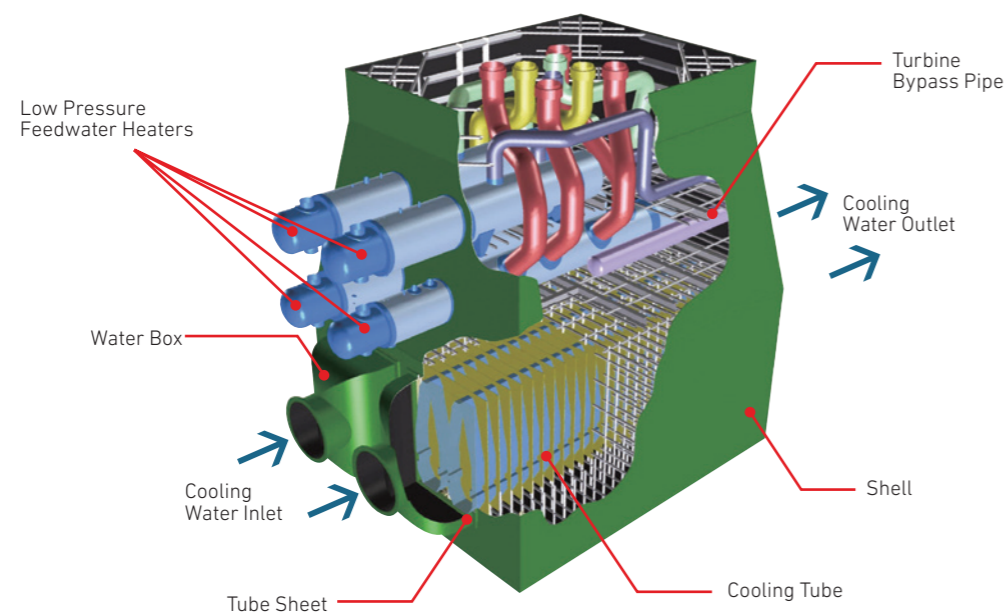

Condenser

Moisture Separator Reheater

Moisture Separator Reheaters (MSRs), which are installed between HP (High Pressure) and LP (Low Pressure) turbines, are heat exchangers to remove moisture and to reheat the steam from high pressure turbine. By using MSR, erosion/corrosion on LP turbine blade is prevented and approx. 2.5% of plant efficiency is enhanced.

HPV (High Performance Vane) developed in-house is applied as moisture separator to realize the residual moisture content of 0.25% or lower. 2-stage reheating structure using HP turbine extraction steam and main steam is employed to gain high efficiency. The reheaters use fin tube made of ferrite stainless steel taking maximization of effective heat transfer area and manufacturability into account.

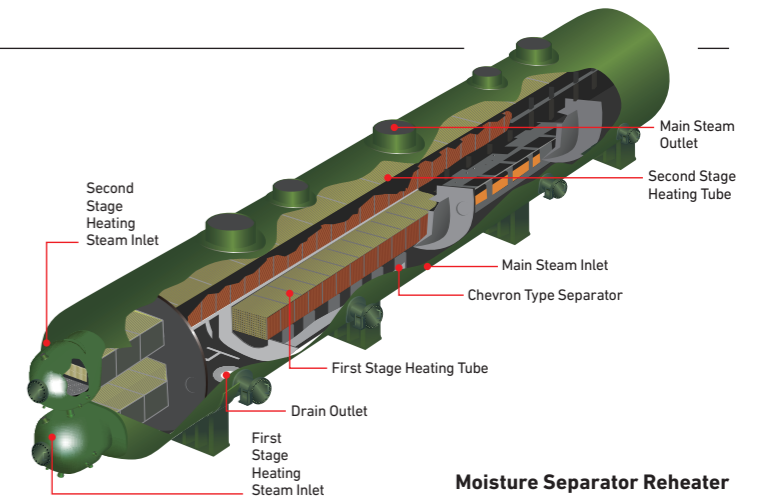

Moisture Separator Reheater

Feedwater Heater

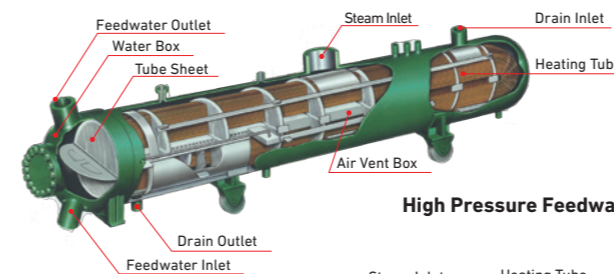

High Pressure Feedwater Heater

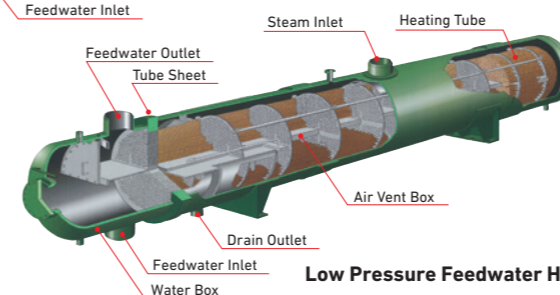

Low Pressure Feedwater Heater

Feedwater heater is a shell & tube type heat exchanger, which heats feedwater through heating tubes by turbine extraction steam. Feedwater heaters which receive extraction steam from HP and LP turbine are called HP and LP feedwater heaters, respectively.

Such a structure as drain cooling zone for heat exchange between extraction drain and feedwater is installed in the shell. The heating tube material is stainless steel having superior corrosion resistance. The heating tube is expanded and seal welded to tubesheet as prevention against leak. (HP feedwater heater) In general, LP feedwater heaters are installed at shell skirt of Condenser in 2 to 4 stages, contributing to compact design of turbine building.

Deaerator

Deaerator is a heat exchanger where condensate is heated up through a direct contact with turbine extraction steam, as well as it deaerates dissolved oxygen in the condensate to 5 ppb or lower.

Mitsubishi Power can supply two types of Deaerator; one is double-shell type deaerator, consisting of a deaerator heater with spray nozzle, deaerator tray, and storage tank, and the other is single-shell type deaerator housing spray nozzle and sparger pipe in storage tank together.

The double-shell type deaerator is constructed so that condensate water is sprayed from the topmost part of the deaerator. While the condensate is dropping down from the tray, the condensate is heated by extraction steam and is deaerated. The condensate is then stored in large-capacity storage tank placed right below the deaerator heater. The single-shell type deaerator is constructed so that the condensate is heated, deaerated and stirred by directly injecting steam into stored feedwater in the tank, as well as condensate is sprayed from the topmost part of the deaerator.

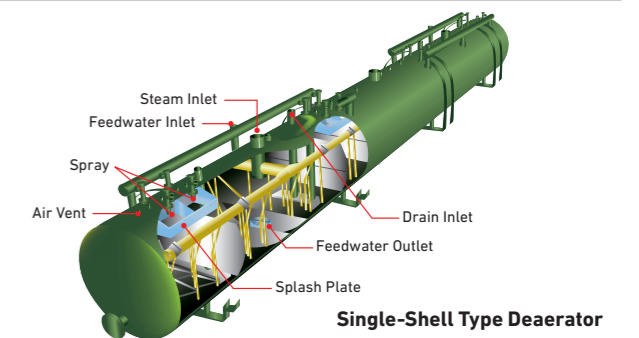

Single-Shell Type Deaerator

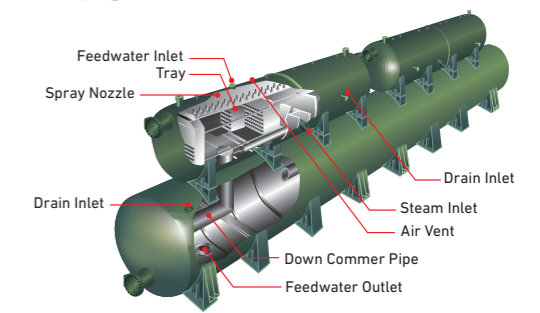

Double-Shell Type Deaerator

Other Heat Exchanger

Mitsubishi Power also manufacture other kinds of heat exchangers which are important for the operation of steam turbine or turbine

plant, such as Gland Steam Condenser & Exhaust Fan, Lube Oil Cooler, Cooling Water Cooler.

Major Pumps

Key pumps in turbine plant are manufactured in house by MHI .

High Pressure & Temperature
Main Feedwater Pump

Large Capacity
Circulating Water Pump
with Variable Pitch Vane

Vertical Pit Barrel Type
Condensate Pump

MHI (Mitsubishi Heavy Industries, Ltd.) provides major pumps in turbine plant.

Main feedwater pump, working together with Feedwater booster pump, delivers feedwater from Deaerator to Steam Generator. Its capacity is large and suitable for use under high pressure and high temperature conditions. Main feedwater pump is made in single stage / double suction / double volute type, driven by the electric motor or steam turbine, and could be usually installed with 3 or 4 sets with the capacity of 33%-50% in accordance with the plant capacity. Main feedwater pump and feedwater booster pump can be arranged on the same drive axis or separately.

Circulating water pump delivers cooling water to Condenser. It is

constructed vertically for mixed flow with large capacity and low head. MHI is capable of manufacturing world's largest type Circulating water pump, which enables the installation with 2 sets of 50% capacity pump (in the case of seawater cooling) contributing to downsizing of intake pit and pump house. Circulating water pump of variable pitch vane type could also reduce the running cost by optimizing the vane angle in accordance with operation conditions.

Condensate pump delivers the condensate water to Deaerator through Gland steam condenser, Condensate Polisher, and Feedwater Heaters. Condensate pump is made in a vertical pit barrel type with multi-stage, driven by the electric motor, and could be installed with 3 sets of 50% capacity.



Main Feedwater Pump (MHI)



Circulating Water Pump (MHI)

Total Engineering

Mitsubishi Power has built up plant total EPC (Engineering, Procurement, and Construction) capability through vast experiences and excellent performances of thermal and nuclear power plants. Mitsubishi Power can offer any services from design to maintenance service of turbine plant.

Design

We design structures, systems and components which meet Customer's requirements. 3D modeling method integrated with database is applied for space design, aiming at highly efficient designing. This method helps not only to enhance operability and maintainability, but also to remarkably reduce reworks at local site. Special verification process is taken in case the FOAK (First-of-a-kind) design or technology is adopted. Senior experts from a lot of engineering fields take part in this review, and verify from several viewpoints such as manufacturability, operability, and reliability. In addition to calculations and simulations, the new technology is verified to function properly through laboratory mockup test or at plant commissioning test.

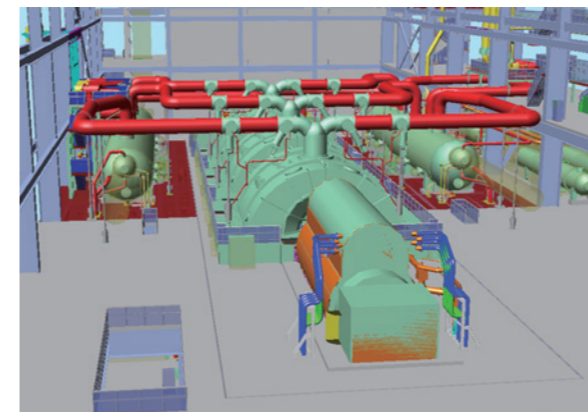

3D model

Procurement

Mitsubishi Power has established worldwide supply chains to provide high quality products and services. Equipment suppliers to nuclear turbine plant are qualified and listed by us. Especially, major components such as pumps and heat exchangers, which are important for plant reliability, are purchased from vendors who have sufficient supply experiences to nuclear power plants. Procurement activity can be effectively conducted through our global network.

We collaborate with vendors, studying their various proposals, so that we can facilitate short-term delivery at reasonable prices. Working in collaboration with the local companies is also developed. They are very familiar with local regulations and standards to be applied, especially in civil engineering work.

Manufacturing

Major products like steam turbines and MSR are manufactured and assembled in our own works.



Press Machine



Rotor Machining



Blade Inspection



Turbine Rotor

Procedures and instructions for manufacturing / fabrication are established as company standard, but those technical know-hows that are hard to put into words need to be passed over by traditional human interactions. To further promote this movement, Mitsubishi Power has launched "Education and Training Center of Technical and Human Skill," where well skilled workers hand down their expertise to younger generations aiming to enhance techniques. Step-up education for senior employees is implemented to further improve their specialty.



Education and Training Center of Technical and Human Skill

Construction

Mitsubishi Power implement site preparation, building construction, and installation of facilities / components. In order to shorten the construction time, several construction methods are adopted. Components are pre-fabricated with piping and valves at shop or site into a big module, and they are installed by using super-crane. Also, simultaneous construction procedure, which building work and installation work are executed at the same time, is applied. Compared with the conventional method, carry-in of bigger component module could be available. Further, pre-fabrication of steel structure shipped with temporary parts to steel frame / beam contributes to reduce construction period at site.

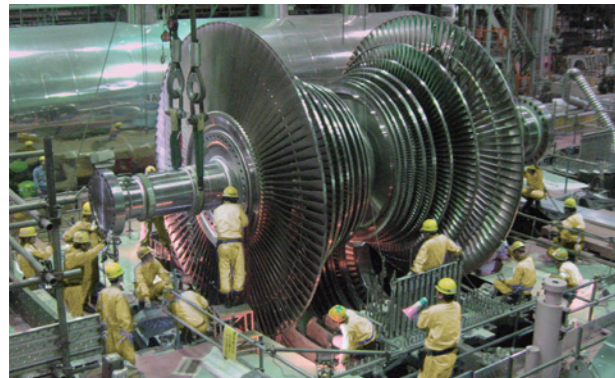

Turbine Installation



Turbine Construction

Commissioning

At the final stage of the plant construction, commissioning of the components and systems is performed. Our startup engineers with plentiful skills and experiences train customers' operators to let them surely master functions, controls, operations, and daily inspections of nuclear turbine plant. We also offer classroom training sessions to educate system design philosophy, abnormal operation and limitations, and component maintenance.

Maintenance Service

Even after commercial operation of the plant, Mitsubishi Power would be a good partner with Customers of maintenance services.

As general maintenance service, we supply consumable parts and spare parts, dispatch technical advisers for disassembling and inspection, and implement work at periodic inspection.

We are proposing long-term maintenance menu also. It widely covers engineering supports such as plant performance evaluation and monitoring of pipe wall thinning, and replacement & modification of major components & systems such as turbine generator and heat exchangers. We have provided lots of these services home and abroad through our total engineering and manufacturing capability.

Mitsubishi Power will solve Customer's needs to improve plant performance, reliability, and operability as well as to reduce maintenance cost throughout plant life. We will provide these services through the nearest branches from customers with close and swift collaborations.

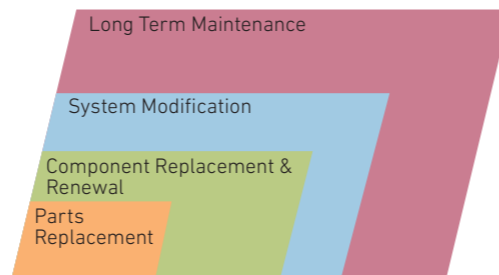

Wide Range of Maintenance Services

Epilogue

We hope you are now familiar with Mitsubishi Power and our nuclear turbine plant. We keep in mind our mission and continue to provide safe and stable electricity through our nuclear turbine plant to customers and people all over the world. If you have any questions about Mitsubishi Power nuclear turbine plant or any problems at your plants, please inform us freely. We believe we can be of help in one way or another.

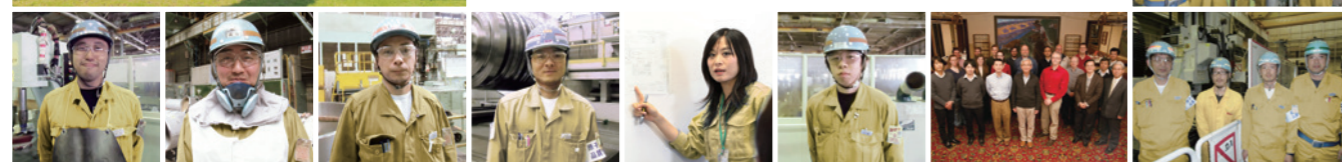

TECH CLOSE UP

Mitsubishi Power New Steam Turbine with 1880™ Last Stage Blade

More than 10 MW* increase of output from the current leading previous 1375mm Last Stage Blade model. Advanced technology based on abundant experience, and Verified design by the largest class in-house test facility and reviewed by the third-party

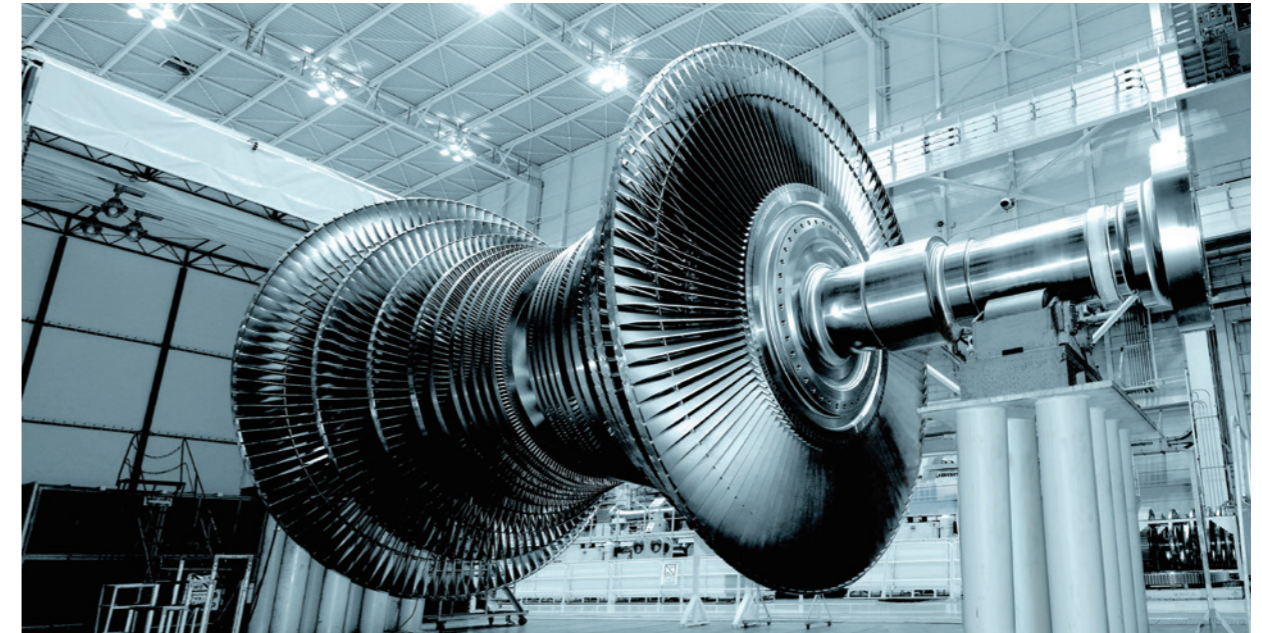

Advanced and Reliable together

Mitsubishi Power 1880™ Last Stage Blade (LSB), the world longest class LSB not only for 50 Hz but for 60 Hz regions, was produced by our advanced technology based on abundant experience over 50 years as the manufacturer of Steam Turbine for Nuclear Power Plant all over the world. In order to reduce the risk of vibration of blade which may lead to the operational failure, the integrity of 1880™ LSB was verified through a) the dynamic stress test which examined the vibrational and centrifugal stress at the world largest class in-house test facility with the half or larger scaled model test rotor, and b) the rotation vibration test which examined the blade natural frequencies with the full scaled test rotor. Moreover, in order to increase the validity of 1880™ LSB design, the design and its design verification process were reviewed by third party and concluded as consistent with the best practice in the industry. This design verification process was applied to the 1375 mm LSB, which has good operational records in 50 Hz and 60 Hz regions. Applying the same verification process to 1880™ LSB, it achieves high reliability.

* The increase may differ depending on its operational conditions. 1880™ is a trademark of Mitsubishi Power. Names of reactor types are trademarks or registered trademarks of their respective owners.

Mitsubishi Power Steam Turbine with 1880™ LSB

Output range	MWe	From 1000 to 2000
Speed	rpm (Hz)	1500 (50) / 1800 (60)
Last stage blade length	mm (inch)	1880 (74)
Number of LP Turbines		2 or 3
Turbine Foundation size	m	20 (Width) 58 (Length for 2 LPTs)

Pursuit of Economic Efficiency

Mitsubishi Power Steam Turbine with 1880™ LSB will produce more output than 1375 mm LSB model even with reduced number of LP turbine (LPT) cylinders to two cylinders. In order to optimize the economic efficiency of the Turbine Island, the number of cylinders of LPT should be selected appropriately based on the reactor type and condenser vacuum pressure. Mitsubishi Power 1880™ LSB Steam Turbine will definitely give the economic efficiency to the customer with the reliable technology.

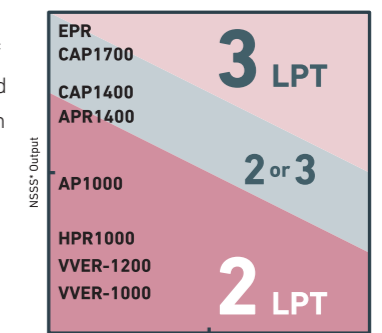

LPT cylinders application chart for 1880™ LSB
*NSSS: Nuclear Steam Supply System