

# FT8<sup>®</sup> Control Upgrade with GEN II Software

## GEN II - YOUR BEST CHOICE FOR PRIMARY TURBINE CONTROL

Mitsubishi Power Aero offers our advanced and proven GEN II control system based upon Woodward GAP™ and Citect HMI software. Coupled with the highly reliable Woodward MicroNet™ Plus hardware platform, it provides FT8 gas turbine fleet customers with consistent and rapid control of their multi-shaft, high-speed, light-inertia turbine systems while providing them the flexibility to make software changes independently. The GEN II control software evolved through work with our affiliate, Energy Services LLC, which implemented this architecture on over 100 turbine controls retrofit projects featuring various OEMs' gas turbines. Operators and asset owners can realize significant benefits with our robust and reliable high-speed gas turbine control system: enhanced troubleshooting, flexibility for customer to change logic, improved maintainability, and continued OEM support.

### KEY FEATURES OF GEN II CONTROLS

- Instantaneous full output capability of the battery (less than 0.1 second)
- Reliability – Redundant CPU, Network, and CAN-Bus communication; Woodward industrial control modules have operated reliably for over 25 years
- Accuracy and Speed – Consistent and dependable control execution in the 5 to 10 millisecond range for critical, heavily loaded controller events (e.g., surge and flame detection and overspeed)
- Customer Interface – Performance monitoring capabilities; customized, online-programmable alarm set points; and discrete and analog trending capabilities
- Open Architecture Logic Diagrams – Real-time viewing of all control logic for rapid diagnostic capability and minimized downtime
- Maintenance / Diagnostics – Hot-swappable modules; high-speed data logs; logic diagrams allowing online adjustments; active HMI interface with individual devices and corresponding schematics
- Training and Documentation – Tailored to customer requirements; turbine model simulation for virtual plant operation and system familiarity
- Emissions Control – Tunable schedules to help meet emissions requirements; integrable, third-party emissions monitoring systems such as CEMS to enable closed loop NOx control

### CONTROLS UPGRADE SCOPE FLEXIBILITY

Mitsubishi Power Aero offers flexible and scalable upgrade solutions to meet customer needs. Upgrades can be deployed to satisfy customer budgetary requirements.

- Modernization flexibility allows you to choose upgrades that optimize your system controls.
- Our control architecture and software standardization minimize downtime during migration to next generation technology.
- Commissioning time and cost are reduced by using fully validated control software tested via high-accuracy simulation software.
- Advanced Operator Training – On-site control training offered to customers with site simulation software, assuring customer familiarity with control software functionality prior to plant operation.

### OEM SUPPORT AND SPARE PARTS

Mitsubishi Power Aero offers sustained, full support from OEM engineers with gas turbine system and product expertise to support control system retrofits and upgrades. We can support all FT8 customers with à la carte parts and service, but some services are accessed more efficiently when part of a fully integrated OEM system solution (e.g., engineering support, lease engines, remote monitoring, and field service).



### CYBERSECURITY

- NERC compliant-capable network, computers, and control system
- CPUs available with a cyber protection package, including secure password authentication, firewall, and encrypted communication tested to Achilles™ Level 1

### UPGRADES FOR GAS TURBINE OEMS

Mitsubishi Power Aero and Energy Services have implemented upgrades and retrofits on installations powered by various gas turbine engines:

- Mitsubishi Power Aero FT8® and FT4000®
- GE LM6000
- Westinghouse 501
- GE LM2500/LM2500+
- Rolls-Royce Trent 60 (Siemens SGT-A65)
- Pratt & Whitney FT4

### BALANCE OF PLANT PLC/DCS SERVICES

Mitsubishi Power Aero provides flexible BOP solutions to meet customer requirements. We have experience working with equipment and controls supplied by numerous OEMs including Rockwell/Allen-Bradley, Honeywell, Siemens, Emerson, and ABB.

For more information, please contact your Customer Service Manager.

GII-FS-1021

Copyright © 2021 Mitsubishi Power Aero LLC

### DESIGN FEATURES FOR MULTIPLE OEM POWER PLANTS

Mitsubishi Power Aero has experience with the same software and hardware controlling multiple OEM gas turbines. We can customize a solution to meet your specific needs.

- HMIs with identical "look and functionality" allow simplified cross-training for operators.
- Common diagnostic and reporting features improve troubleshooting.
- Standard control design allows for reduced spares inventory and operator familiarity.
- Multilingual capability within the HMI addresses global market requirements.

### MICRONET PLUS DISTRIBUTED I/O

- Dual CPUs, Single GW, Simplex Nodes

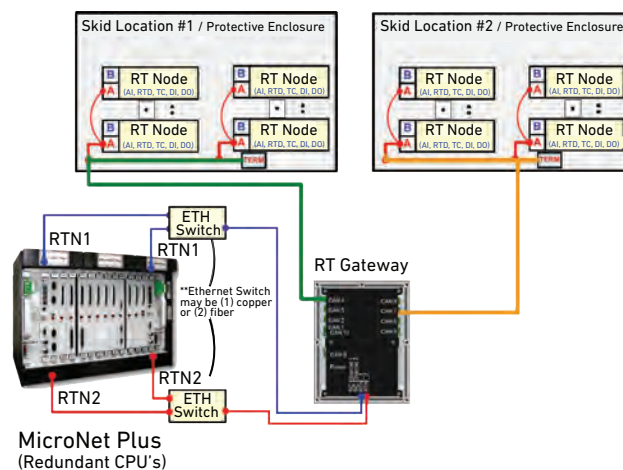

### CUSTOMER VALUE

Mitsubishi Power Aero has provided innovative, high-quality control system solutions to the power industry for over 50 years. Our versatile engineering teams have extensive experience developing systems for power generation applications for multiple OEMs. Our dedicated field service group and customer support engineers ensure collaboration from product and system experts throughout the life cycle of your equipment.

FT8® and FT4000® are trademarks of Mitsubishi Power Aero LLC

Mitsubishi Power is a power solutions brand of Mitsubishi Heavy Industries.

**Mitsubishi Power Aero LLC**  
 628 Hebron Avenue, Suite 400  
 Glastonbury, CT 06033 USA  
 +1-860-368-5900