

LSSCG02 Super Scanner Gateway module

Gigabit Ethernet 1000BASE-T Specification compliance Bridge unit for D-Ring (For MPS communication)

■ Summary



* Major function : MPS-Ring communication bridge

* Module ambient temperature : -5 to 60°C

LSSCG02 Super Scanner Gateway module

Gigabit Ethernet 1000BASE-T Specification compliance Bridge unit for D-Ring (For MPS communication)

■ Specifications

ITEM		SPECIFICATION	
Function		D-Ring (Giga-bit Ethernet ring communication)	
Number of D-Ring addressing node		Maximum 32 node	
EEPROM		2kbit (For initial setting information of MAC address)	
Ethernet interface	For D-Ring	1000BASE-T	:2
	For MPS communication	1000BASE-T	:2
	For maintenance	100BASE-T	:1
User interface	Micro SD card		:1
	Control/standby switch		:1
	Reset switch		:1
	USB mini-B		:1
Controller		Xilinx Spartan6 XC6SLX100	
Self-diagnostic functions		Clock abnormal check CRC check (FPGA) Memory check Power voltage check Configuration check	
Data check method		CRC32	
Indicator		4 : PWR(Power) / STS(Status) / MOD(Mode) / ACC(Access)	
Hot swap		Possible	
Power supply		DC 24V ±20% (The voltage supplied from the backplane)	
Environmental conditions	Module ambient temperature	(Operating) -5 to 60°C (Storage) -40 to 85°C	
	Module ambient humidity	10 to 95% RH or less (No condensation)	
Vibration		3.5mm @5 to 8.4Hz 1G @8.4 to 150Hz	
Shock		15G 11ms	
Current consumption		Less than 329mA	
Weight		0.27kg	
Dimensions		112mmD x 117mmH x 46mmW (Except projection)	
Standard/Directive		IEC61131-2-2007, RoHS	

*About compliant module type

For compliant modules of this product, please refer to "Compliant backplane list (CGS-S9901-E-XX)".

LSSCG02 Super Scanner Gateway module

Gigabit Ethernet 1000BASE-T Specification compliance Bridge unit for D-Ring (For MPS communication)

■ Block diagram

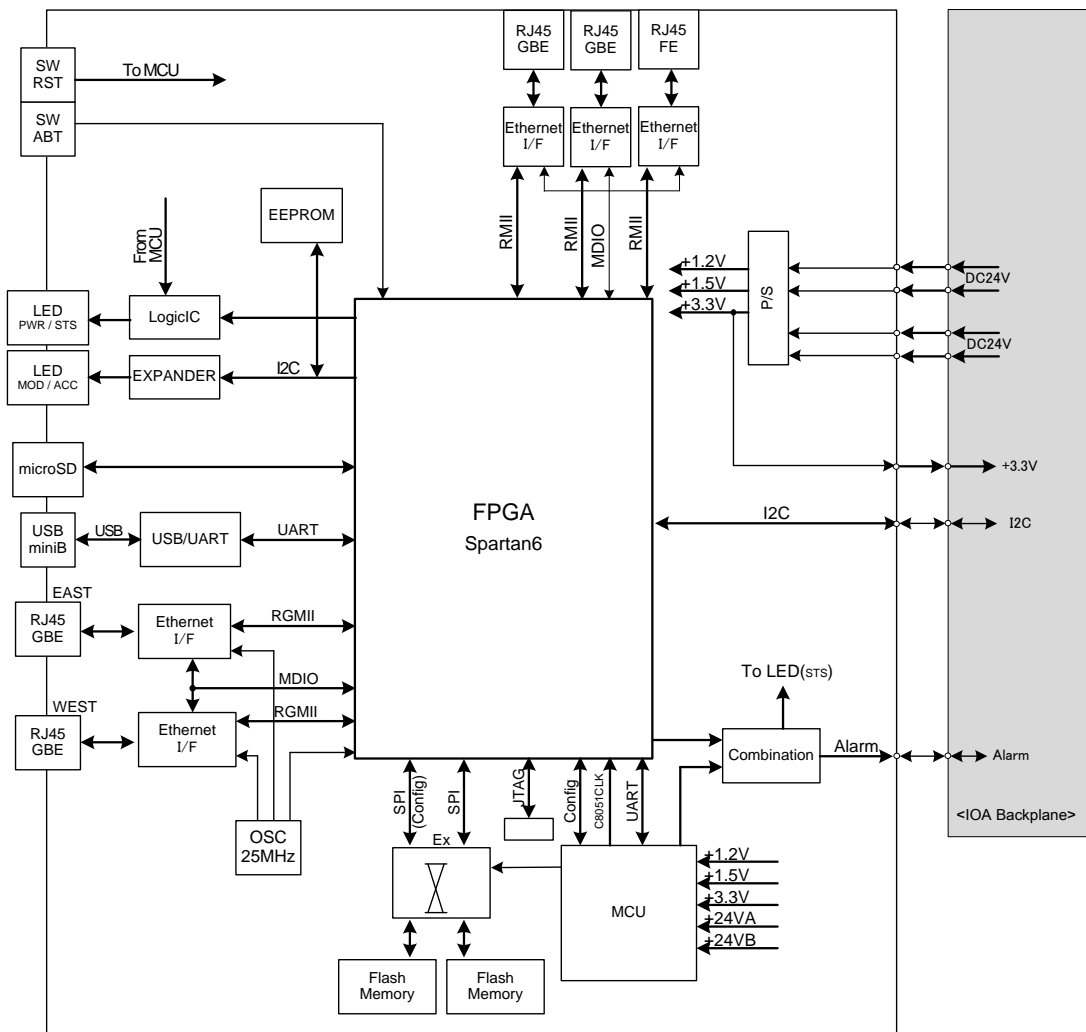

P/S	:	Power Supply
I2C	:	Inter-Integrated Circuit
RJ45_FE	:	RJ45 connector _ Fast Ethernet
RJ45_GBE	:	RJ45 connector _ Giga bit Ethernet
RMII	:	Reduced Media Independent Interface
MDIO	:	Management Data Input/Output Bus
FPGA	:	Field Programmable Gate Array
MCU	:	Micro controller Unit
UART	:	Universal Asynchronous Receiver Transmitter
JTAG	:	Joint Test Action Group
SPI	:	Serial Peripheral Interface
Flash	:	Flash memory
Ex	:	Exchange device
CLK	:	Clock Oscillator
OSC	:	Oscillator
EEPROM	:	Electrically Erasable Programmable Read-Only Memory
SW_RST	:	Reset switch
SW_ABO	:	Abort switch
LED	:	Light Emitting Diode
PWR/STS	:	Power/Status
MOD/ACC	:	Mode/Access

When using, please read the instruction manual attached to the product carefully and use it properly.

This catalog may not be distributed or reproduced in whole or in part without permission.

Please be aware that due to product improvements and modifications, the product description in this catalog may differ in certain respects from the actual product.

DIASYS Netmation/DIASYS Netmation4S is a registered trademark of Mitsubishi Hitachi Power Systems, Ltd.

The service names and product names of other companies described in this catalog are the trademarks or registered trademarks of each company.