

# LSIOA01 IO adapter module

Gigabit Ethernet 1000BASE-T Specification compliance

## ■ Summary



- \* Major function : Giga-bit Ethernet-LVDS communication bridge
- \* Module ambient temperature : -5 to 60°C

# LSIOA01 IO adapter module

## Gigabit Ethernet 1000BASE-T Specification compliance

### ■ Specifications

ITEM		SPECIFICATION
Function		I/O module communication (LVDS) Giga-bit Ethernet ring communication
Communication rate (LVDS)		100Mbps
Number of D-Ring addressing node		Maximum 96 node
EEPROM		2kbit (For initial setting information of MAC address)
Ethernet interface	For D-Ring	1000BASE-T :2
User interface		Micro SD card :1 Control/standby switch :1 Reset switch :1 USB mini-B :1
Controller		Xilinx Spartan6 XC6SLX100
Self-diagnostic functions		Clock abnormal check CRC check (FPGA) Memory check Power voltage check Configuration check
Data check method		CRC32
Indicator		4 : PWR(Power) / STS(Status) / MOD(Mode) / ACC(Access)
Hot swap		Possible
Power supply		DC 24V ±20% (The voltage supplied from the backplane)
Environmental conditions	Module ambient temperature	(Operating) -5 to 60°C (Storage) -40 to 85°C
	Module ambient humidity	10 to 95% RH or less (No condensation)
Vibration		3.5mm @5 to 8.4Hz 1G @8.4 to 150Hz
Shock		15G 11ms 0.5J ±0.04J
Current consumption		Less than 305mA
Weight		0.24kg
Dimensions		112mmD x 117mmH x 46mmW (Except projection)
Standard/Directive		IEC61131-2-2007, RoHS

\*About compliant module type

For compliant modules of this product, please refer to “Compliant backplane list (CGS-S9901-E-XX)”.

# LSIOA01 IO adapter module

Gigabit Ethernet 1000BASE-T Specification compliance

## ■ Block diagram

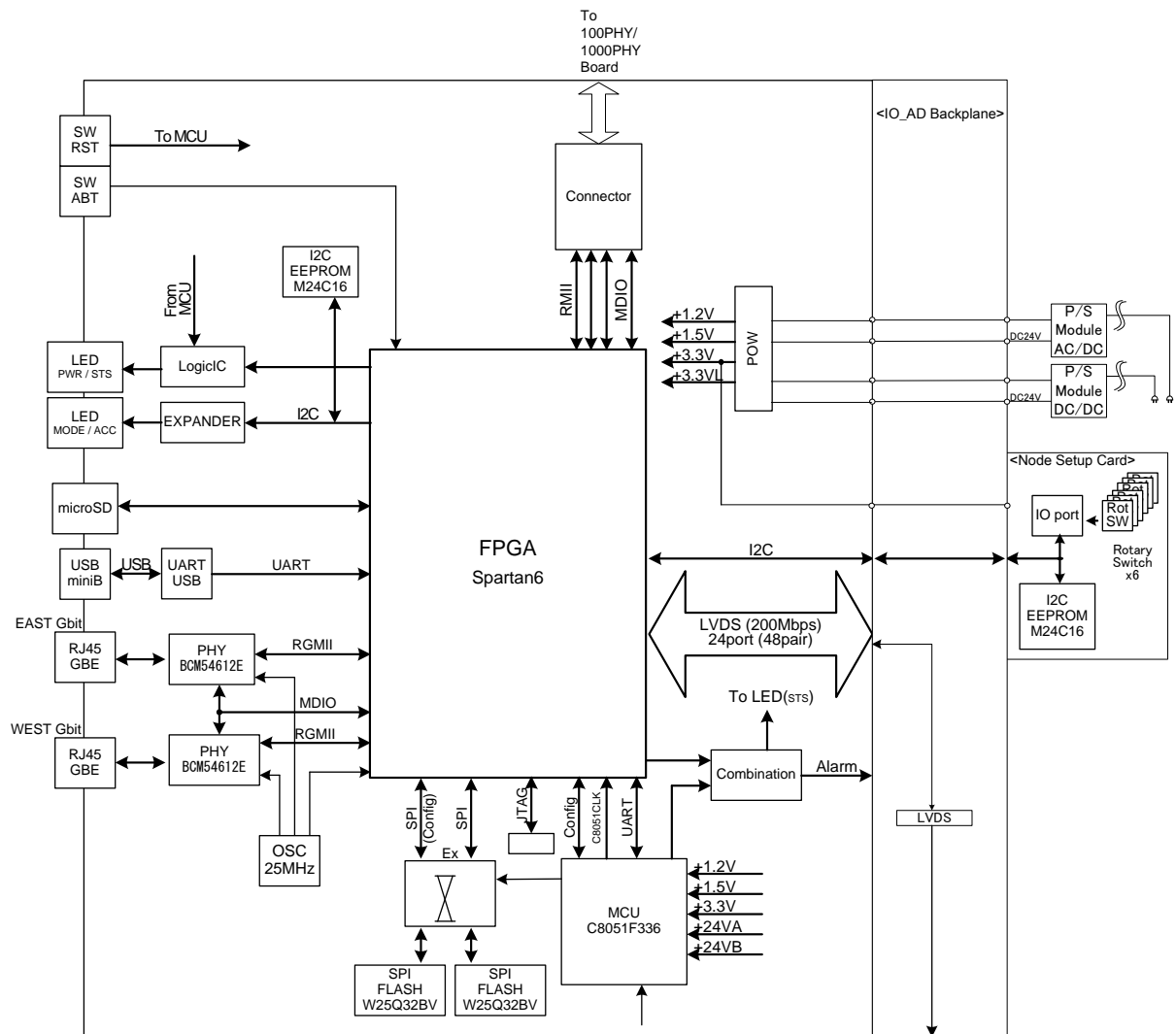

- |        |   |   |
|--------|---|---|
| P/S    | : | Power Supply  |
| IO_AD  | : | Input/Output Adapter                                |
| LVDS   | : | Low Voltage Differential Signaling                  |
| FPGA   | : | Field Programmable Gate Array                       |
| MCU    | : | Micro controller Unit                               |
| Flash  | : | Flash memory  |
| CLK    | : | Clock Oscillator                                    |
| OSC    | : | Oscillator  |
| RST    | : | Reset   |
| LED    | : | Light Emitting Diode                                |
| ABO    | : | Abort   |
| PWR    | : | Power   |
| STS    | : | Status  |
| GBE    | : | Giga bit Ether                                      |
| UART   | : | Universal Asynchronous Receiver Transmitter         |
| EEPROM | : | Electrically Erasable Programmable Read-Only Memory |
| SPI    | : | Serial Peripheral Interface                         |
| DDR3   | : | Double Data Rate3                                   |
| I2C    | : | Inter-Integrated Circuit                            |
| JTAG   | : | Joint Test Action Group                             |

When using, please read the instruction manual attached to the product carefully and use it properly.

This catalog may not be distributed or reproduced in whole or in part without permission.

Please be aware that due to product improvements and modifications, the product description in this catalog may differ in certain respects from the actual product.

DIASYS Netmation/DIASYS Netmation4S is a registered trademark of Mitsubishi Hitachi Power Systems, Ltd.

The service names and product names of other companies described in this catalog are the trademarks or registered trademarks of each company.