

FXPIM01A Pulse input module

ControlNet™ FLEX I/O™ DC 24 V pulse inputs : 8

*ControlNet™ is ControlNet International's registered trademark.
*FLEX I/O™ is Rockwell Automation's registered trademark.



■ Outline

- * Number of inputs : 8
- * Input pulse rate : 0 to 500 Hz
- * Rated input voltage : DC 24 V
- * FLEX I/O™ / ControlNet™ LAN compatible

ITEM	SPECIFICATION
Number of inputs	8
Isolation	Opto-isolation Current sourcing input with a (-)common return
Rated input voltage	DC 24 V
Rated input current	5 mA
Minimum ON current	1.8 mA
Input pulse rate	0 to 500 Hz (ON-time should be above 0.5 msec)
Input filter	Digital filter 0 ms, 5 ms, 10 ms, 50 ms (Program selectable, whole channels batch setting)
Self-diagnostic functions	Watchdog timer Power supply voltage low Bus time-out
Indicator	LED × 1 2 Modes Green (Normal) Red (Abnormal) LED × 8 Yellow (ON) Off (OFF)
Compatible terminal bases	1794 - TB3/TB3S 1794 - TBN/TBNF
Dielectric strength	AC 1500 V Between input terminal and FG (1 min.)
Environmental conditions	(Operating) Temperature: 0 to 55°C Humidity: 5 to 95% RH (No Condensation) (Storage) Temperature: -40 to 85°C Humidity: 5 to 95% RH (No Condensation)
Power supply	DC 24 V ±10% / Less than 60 mA DC 5 V / Less than 80 mA (FLEX BUS)
Shock/Vibration	15 G / 2 G @ 10 to 500Hz
Dimensions	75 mm (D) × 46 mm (H) × 94 mm (W)

This product uses technology licensed from Rockwell Automation Technologies, Inc.

FXPIM01A Pulse input module

ControlNet™ FLEX I/O™ DC 24 V pulse inputs : 8

*ControlNet™ is ControlNet International's registered trademark.
*FLEX I/O™ is Rockwell Automation's registered trademark.

FXPIM01A block diagram

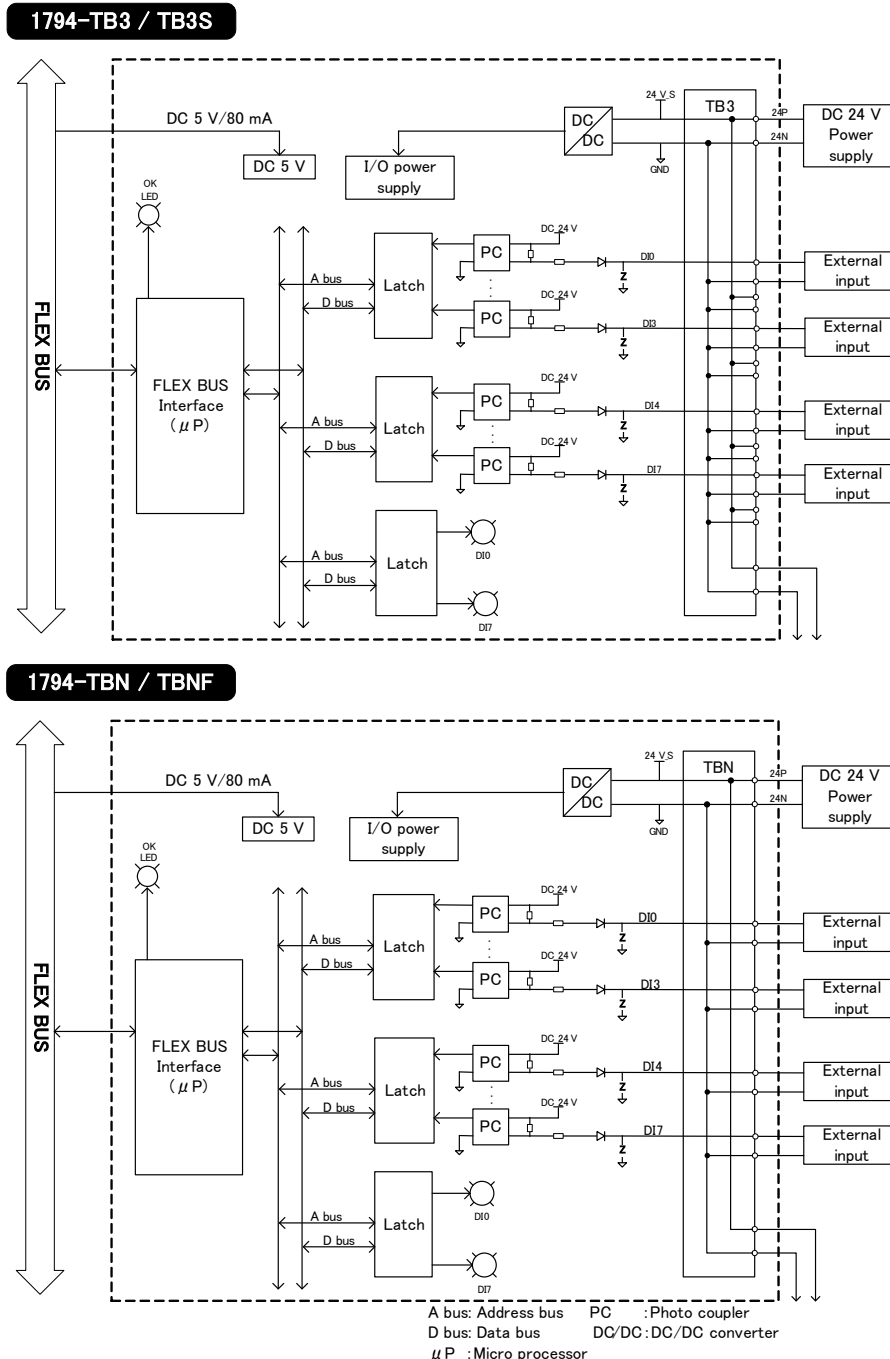

When using, please read the instruction manual attached to the product carefully and use it properly.

This catalog may not be distributed or reproduced in whole or in part without permission.

Please be aware that due to product improvements and modifications, the product description in this catalog may differ in certain respects from the actual product.

DIASYS Netmation/DIASYS Netmation4S is a registered trademark of Mitsubishi Heavy Industries, Ltd.

The service names and product names of other companies described in this catalog are the trademarks or registered trademarks of each company.