

FXVIF04B-□□ Valve interface module

ControlNet™ FLEX I/O™ Current output type, analog input distributor type, digital input/output DC 24 V



■ Outline

- * Current output type valve interface (4 to 20 mA, I/P converter correspondence)
- * Valve position demand analog output × 1
- * Valve position feedback analog input (distributor type) × 1
- * Universal digital input × 8
- * Universal digital output × 4
- * Selector station interface
 - Analog output × 2
 - Digital input × 6
 - Digital output × 6
- * FLEX I/O™ / ControlNet™ LAN compatible

*ControlNet™ is ControlNet International's registered trademark.
*FLEX I/O™ is Rockwell Automation's registered trademark.

ITEM	SPECIFICATION
Analog output (for valve position demand output)	4 to 20 mA × 1 Load resistance 0 to 550 Ω, Transformer isolation ±0.1% FSD at 4 to 20 mA (Load 250 Ω ±1%) ±100 ppm/°C Equipped with output current monitoring (read-back input)
Analog input (for valve position feedback input)	4 to 20 mA × 1 (Distributor type) Input resistance 249 Ω, Transformer isolation ±0.1% FSD at 4 to 20 mA ±100 ppm/°C
Digital inputs	Opto-isolation Current sinking input with a (+)common × 8 DC 24 V minimum ON current 2.5 mA
Digital outputs	Opto-isolation Sinking output with a (+)common Open collector × 4 Maximum voltage DC 24 V +10% Maximum load current 0.2 A
Selector station interface	Analog output × 2 4 to 20 mA/300 Ω or 1 to 5 V selectable Digital input × 6 (External power supply DC 24 V) Digital output × 6 (Maximum voltage DC 24 V +10% load current 0.1 A)
FPGA type identification code	FXVIF04B-□□ (Module model is expressed with 2 digits of □□)
Self-diagnostic functions	FPGA execution abnormal Connector omission Power supply voltage low Bus time-out Read back abnormal
Indicator	LED × 1 Module status indication LED × 16 System status indication
Compatible terminal base	1794-TB3
Dielectric strength	AC 500 V Between analog I/O terminal and FG (1 min.) AC 1500 V Between digital I/O terminal and FG (1 min.)
Environmental conditions	(Operating) Temperature: 0 to 55°C Humidity: 35 to 95% RH (No condensation) (Storage) Temperature: -10 to 70°C Humidity: Less than 80% RH (No condensation)
Power supply	DC 24 V ±10% / Less than 200 mA DC 5 V ±10% / Less than 80 mA (FLEX BUS)
Shock/Vibration	15 G / 2 G @ 10 to 500 Hz
Dimensions	110 mm (D) × 46 mm (H) × 94 mm (W)

This product uses technology licensed from Rockwell Automation Technologies, Inc.

FXVIF04B-□□ Valve interface module

ControlNet™ FLEX I/O™ Current output type, analog input distributor type, digital input/output DC 24 V

*ControlNet™ is ControlNet International's registered trademark.

*FLEX I/O™ is Rockwell Automation's registered trademark.

FXVIF04B-□□ block diagram

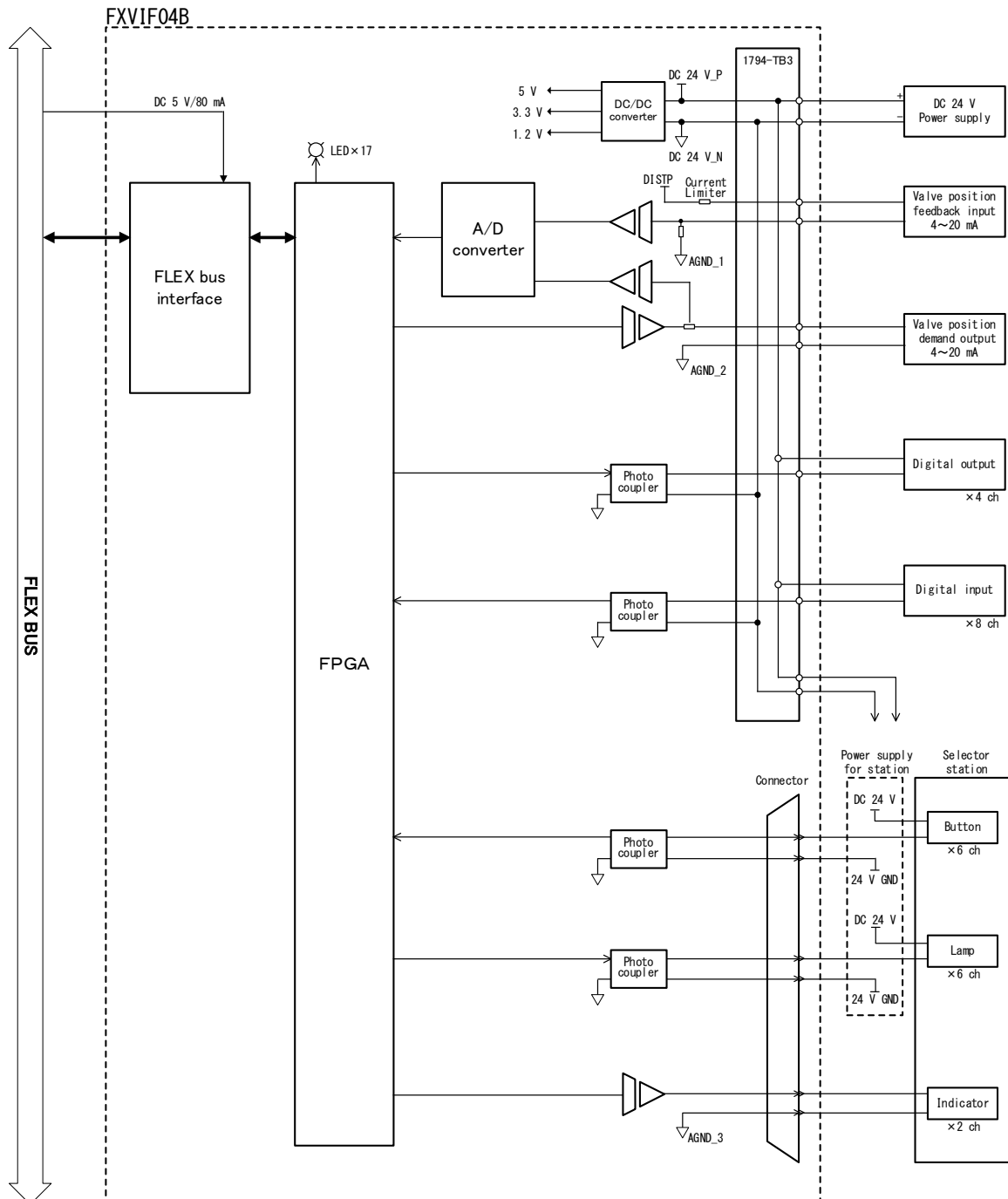

When using, please read the instruction manual attached to the product carefully and use it properly.

This catalog may not be distributed or reproduced in whole or in part without permission.

Please be aware that due to product improvements and modifications, the product description in this catalog may differ in certain respects from the actual product.

DIASYS Netmation/DIASYS Netmation4S is a registered trademark of Mitsubishi Heavy Industries, Ltd.

The service names and product names of other companies described in this catalog are the trademarks or registered trademarks of each company.