

FXSVL02B Servo valve interface module

ControlNet™ FLEX I/O™ Valve position demand output ± 50 mA/ ± 60 mA, position feedback LVDT 6wiring, 8 V, 5 kHz

*ControlNet™ is ControlNet International's registered trademark.

*FLEX I/O™ is Rockwell Automation's registered trademark.



■ Outline

- * Valve position demand output (Output range ± 50 mA/ ± 60 mA) × 1
- * Valve position feedback LVDT × 1
- * Auxiliary interface
- * Module duplicated interface
- * FLEX I/O™ / ControlNet™ LAN compatible

ITEM	SPECIFICATION
Position demand output	± 50 mA/ ± 60 mA
Position feedback	LVDT 6wiring, 8 V, 5 kHz
Digital inputs	Photo coupler input × 2 DC 24 V / 5 mA
Auxiliary inputs (Without isolation)	1 to 5 V DC × 4 Digital input × 5
Auxiliary outputs (Without isolation)	1 to 5 V DC × 3 Digital output × 4
Serial interface (For maintenance)	EIA/RS-232C (PS/2) × 1
Self-diagnostic functions	Application abnormal Watchdog timer Clock monitor Connector omission Power supply voltage low Bus time-out
Indicator	LED × 1 3 Modes Green (Control) Yellow (Standby) Red (Abnormal) LED × 16 Yellow (General Purpose)
Compatible terminal bases	1794-TB3/TB3S 1794-TBN/TBNF
Dielectric strength	AC 500 V Between analog I/O terminal and FG (1 min.) AC 1500 V Between digital I/O terminal and FG (1 min.)
Environmental conditions	(Operating) Temperature : 0 to 55°C Humidity: 35 to 95% RH (No condensation) (Storage) Temperature: -10 to 70°C Humidity: Less than 80% RH (No condensation)
Power supply	DC 24 V $\pm 10\%$ / Less than 300 mA DC 5 V / Less than 80 mA (FLEX BUS)
Shock/Vibration	15 G / 2 G @ 10 to 500 Hz
Dimensions	110 mm (D) × 46 mm (H) × 92 mm (W)

This product uses technology licensed from Rockwell Automation Technologies, Inc.

FXSVL02B Servo valve interface module

ControlNet™ FLEX I/O™ Valve position demand output ± 50 mA/ ± 60 mA, position feedback LVDT 6wiring, 8 V, 5 kHz

*ControlNet™ is ControlNet International's registered trademark.
*FLEX I/O™ is Rockwell Automation's registered trademark.

FXSVL02B block diagram

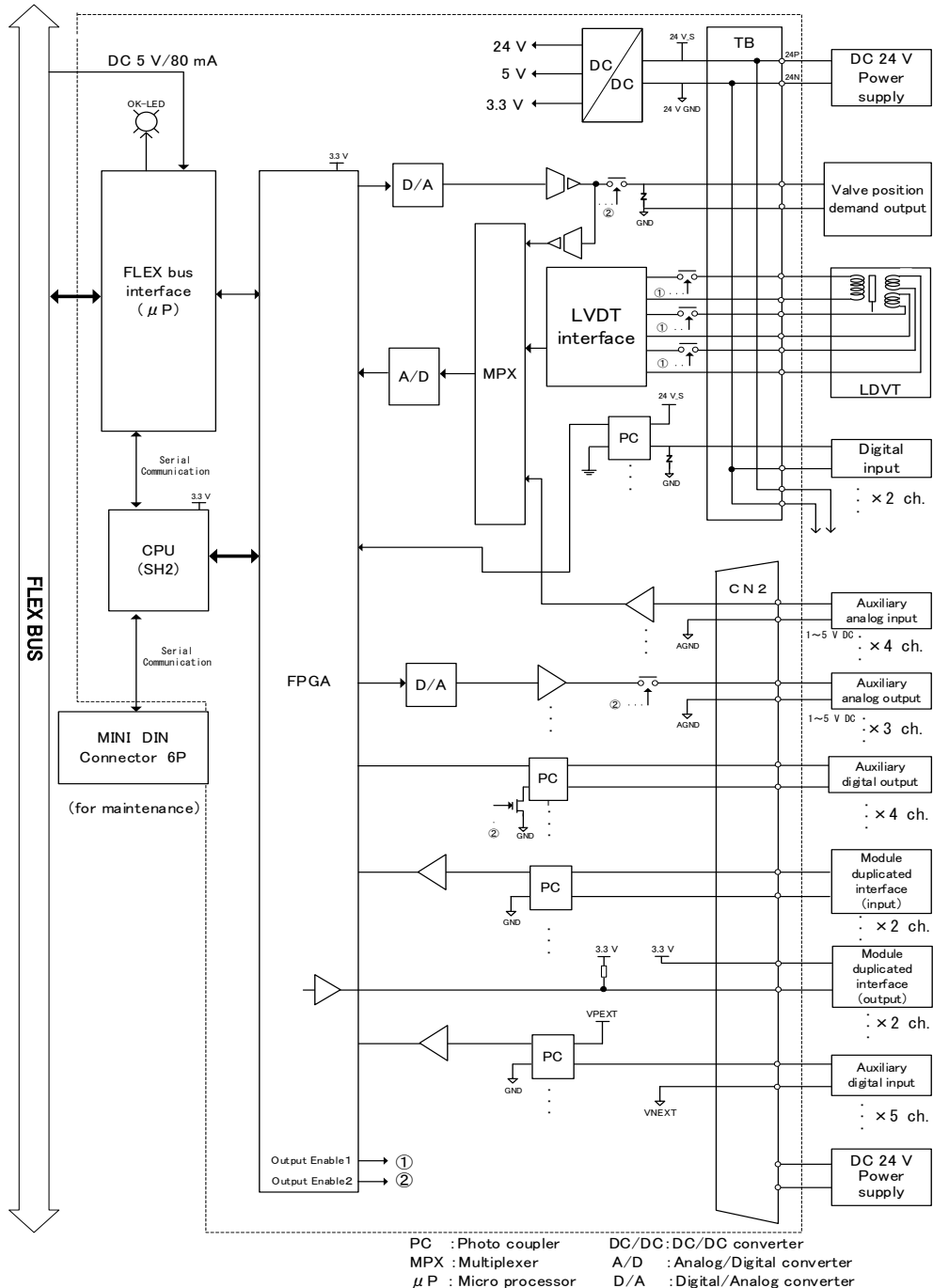

When using, please read the instruction manual attached to the product carefully and use it properly.

This catalog may not be distributed or reproduced in whole or in part without permission.

Please be aware that due to product improvements and modifications, the product description in this catalog may differ in certain respects from the actual product.

DIASYS Netmation/DIASYS Netmation4S is a registered trademark of Mitsubishi Heavy Industries, Ltd.

The service names and product names of other companies described in this catalog are the trademarks or registered trademarks of each company.