

LSRLTS-DI01 FXtoLS Adapter (Type5)

16 Point Negative Common Diode Built-in Type for DIM

Summary



- * Summary : Conversion adapter for mounting D-Ring I/O module on FX terminal block
- * I/O terminal connection : Digital input support for 16 channels (CH1 to CH16) (Integrated Diode for Negative Common)
- * Supported modules : (FX-I/O module)
FXDIM01, FXEDIO2A, FXPIM02A (DC 24 V)
FXDIM02, FXEDIO2B, FXPIM02B (DC 48 V)

(D-Ring I/O module)
LSDIM01-1-R, LSDIM01A-1-R
- * Power supply : DC 24 V (Connector Connection between the FX terminal block)

Specifications

ITEM		SPECIFICATION
Power Specifications	Rated voltage	DC 24 V \pm 20% (Connector connection between the FX terminal block)
	Redundancy method	Independent two-line power supply
Communication method		LVDS
FX terminal block connector	Number of channels	1
	Rated voltage	DC 300 V / AC 264 V
	Rated current	2 A
I/O module connector	Number of channels	1
LVDS communication connector	Number of channels	2
PE connector	Number of channels	1
I/O channel		16 ch (Integrated diode for negative common)
Supported module	FX-I/O module	FXDIM01, FXEDIO2A, FXPIM02A (DC 24 V) FXDIM02, FXEDIO2B, FXPIM02B (DC 48 V) (16 point negative common input)
	D-Ring I/O module	LSDIM01-1-R, LSDIM01A-1-R (16 point negative common input)
Environmental condition	Module ambient temperature	(Operating) 0 to 55°C (Storage) -40 to 85°C
	Module ambient humidity	(Operating / Storage) 5 to 95% RH (No Condensation)
Vibration		3.5 mm @ 5 Hz to 8.4 Hz 1 G @ 8.4 Hz to 150 Hz
Shock		15 G 11 ms
Weight		0.17 kg
Dimensions		55 mm (D) x 94 mm (H) x 46.5 mm (W) (Except projection)
Standard/Directive		IEC 61131-2 : 2017, RoHS directive

(Caution) When replacing from a FX-I/O module to a D-Ring I/O module, carefully check the specifications of the corresponding D-Ring I/O module

LSRLTS-DI01 FXtoLS Adapter (Type5)

16 Point Negative Common Diode Built-in Type for DIM

■ Block diagram

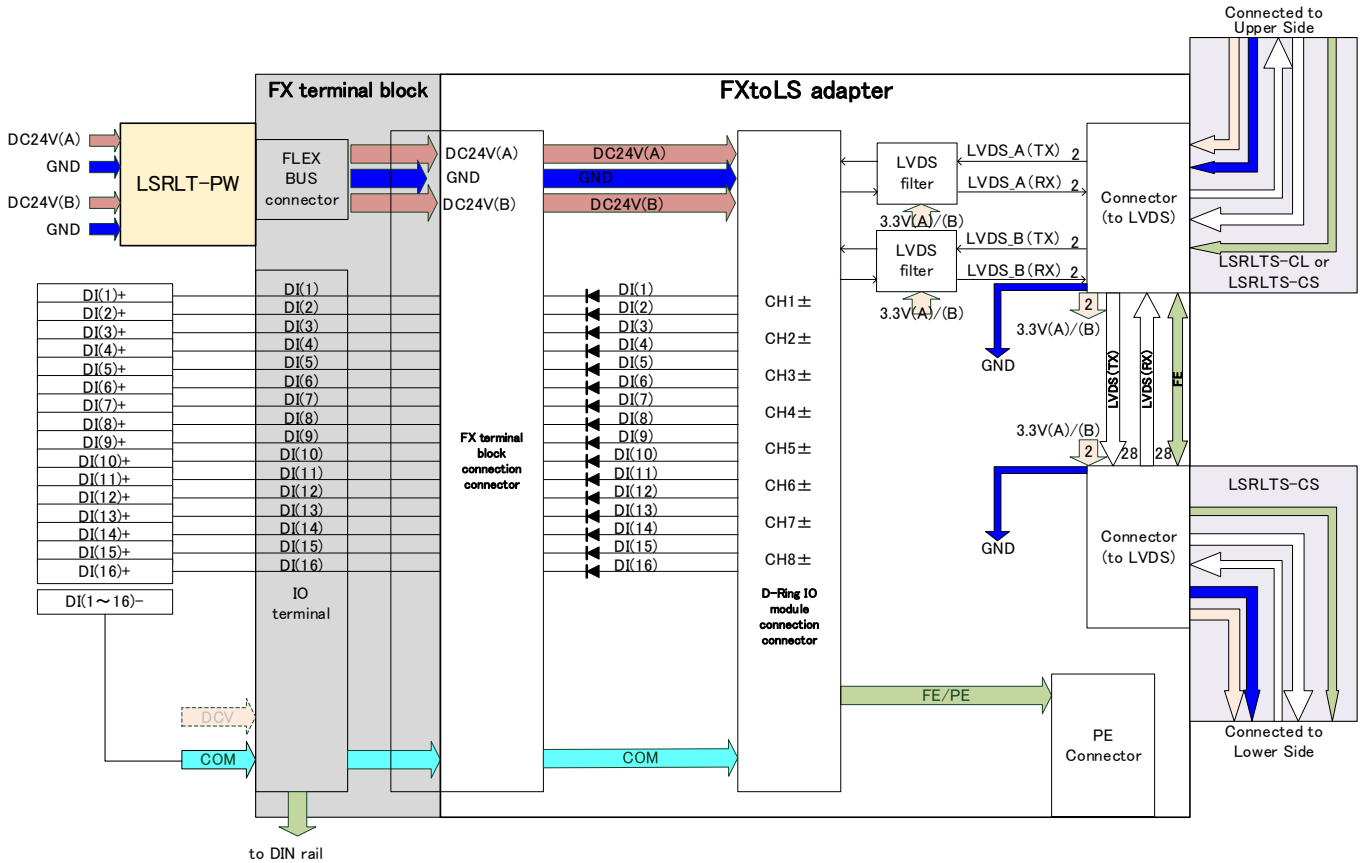

LVDS : Low Voltage Differential Signaling
 GND : Ground
 COM : Common
 FE : Functional Earth
 PE : Protective Earth

When using, please read the instruction manual attached to the product carefully and use it properly.

This catalog may not be distributed or reproduced in whole or in part without permission.

Please be aware that due to product improvements and modifications, the product description in this catalog may differ in certain respects from the actual product.

DIASYS Netmation/DIASYS Netmation4S is a registered trademark of Mitsubishi Heavy Industries, Ltd.

The service names and product names of other companies described in this catalog are the trademarks or registered trademarks of each company.